



# *Fire, Life Safety & Accessibility Codes*

A Reference Guide for Doors & Hardware

## *A Growing Part of Your World*

Ingersoll Rand is a \$17 billion global diversified industrial company, driven by employees who are proud to offer products and solutions people use every day to create a positive impact in their world.

With market leading brands such as Schlage, LCN, and Von Duprin we provide products and services that make environments safe, secure and productive. Our products include electronic access control systems, locks, door controls, exit devices, steel doors and frames, portable security devices, decorative hardware, cabinet hardware and time, attendance and personnel scheduling systems.

Our customers rely on our family of industrial and commercial brands, such as Club Car, Hussmann, Thermo King, and Trane air conditioning systems and services. In every aspect of your daily life, our market-leading brands and the products, services and solutions we offer are a growing part of your world. Chances are that today, one of our brands has helped you or those around you create progress.

*For code questions or to request more copies of this resource,  
contact your local security and safety consultants listed on page 37 of this guide.*

# Table of Contents

DESCRIPTION	PAGE
Classification of Occupancy As Defined By NFPA 101® Life Safety Code® and NFPA 5000™ Building Construction & Safety Code - 2006 Editions . . . . .	4-5
NFPA 101® Life Safety Code® / NFPA 5000™ Building Construction & Safety Code - 2006 Editions . . . . .	6-7
ICC International Building Code® - 2006 Edition . . . . .	8-9
ICC International Building Code® - 2003 Edition . . . . .	10-11
BOCA National Building Code - 1999 Edition . . . . .	12-13
SBCCI Standard Building Code - 1999 Edition . . . . .	14-15
ICBO Uniform Building Code™ - 1997 Edition . . . . .	16-17
NBCC National Building Code of Canada – 2005 Edition . . . . .	18-19
NFPA 80 Standard for Fire Doors and Other Opening Protectives - 2007 Edition . . . . .	20-21
NFPA 80 Standard for Fire Doors and Fire Windows - 1999 Edition . . . . .	22-23
ADA Americans With Disabilities Act - July 23, 2004 Edition . . . . .	24
ICC/ANSI A117.1 Accessible and Usable Buildings and Facilities - 2003 Edition . . . . .	25
De-Coding Panic Hardware . . . . .	26-27
De-Coding Door Closers . . . . .	28-29
De-Coding Stairwell Re-Entry . . . . .	30-31
De-Coding Delayed Egress . . . . .	32-33
De-Coding Access-Controlled Egress Doors . . . . .	34-35
Sources for Code Information . . . . .	36
List of Local Offices . . . . .	37

# Classification of Occupancy & Hazard of Contents

As Defined by NFPA 101® Life Safety Code® & NFPA 5000™ Building Construction & Safety Code (2006)

## Classification of Occupancy (6.1)

The occupancy of a building or structure, or portion of a building or structure, shall be classified as one of the following:

### Assembly

An occupancy (1) used for a gathering of 50 or more persons for deliberation, worship, entertainment, eating, drinking, amusement, awaiting transportation, or similar uses; or (2) used as a special amusement building regardless of occupant load.

#### Assembly occupancies include the following:

- Armories
- Exhibition halls
- Places of religious worship
- Assembly halls
- Gymnasiums
- Pool rooms
- Auditoriums
- Libraries
- Recreation piers
- Bowling lanes
- Mortuary chapels
- Restaurants
- Club rooms
- Skating rinks
- Colleges and university classrooms 50 persons +
- Museums
- Theaters
- Passenger stations and terminals of air, surface, underground and marine public transportation facilities
- Conference rooms
- Courtrooms
- Dance halls
- Drinking establishments
- Motion picture theaters

Occupancy of any room or space for assembly purposes by fewer than 50 persons in another occupancy and incidental to such other occupancy shall be classified as part of the other occupancy and shall be subject to the provisions applicable thereto.

### Educational

An occupancy used for educational purposes through the twelfth grade by six or more persons for four or more hours per day or more than twelve hours per week.

Educational occupancies include the following:

- Academies
- Kindergartens
- Nursery schools
- Schools

Other occupancies associated with educational institutions shall be in accordance with the appropriate parts of this Code.

In cases where instruction is incidental to some other occupancy, the section of the Code governing such other occupancy shall apply.

### Health Care

An occupancy used for purposes of medical or other treatment or care of four or more persons where such occupants are mostly incapable of self-preservation due to age, physical or mental disability or because of security measures not under the occupants' control.

Health care occupancies include the following:

- Hospitals
- Limited care facilities
- Nursing homes

### Ambulatory Health Care

A building or portion thereof used to provide services or treatment simultaneously to four or more patients that provides, on an outpatient basis, one or more of the following:

- 1) Treatment for patients that renders the patients incapable of taking action for self-preservation under emergency conditions without the assistance of others.
- 2) Anesthesia that renders the patients incapable of taking action for self-preservation under emergency conditions without the assistance of others.
- 3) Emergency or urgent care for patients who, due to the nature of their injury or illness are incapable of taking action for self-preservation under emergency conditions without the assistance of others.

### Detention and Correctional

An occupancy used to house four or more persons under varied degrees of restraint or security where such occupants are mostly incapable of self-preservation because of security measures not under the occupants' control. Within detention and correctional facilities, uses other than residential housing shall be in accordance with the appropriate chapter of the Code.

Detention and correctional occupancies include the following:

- Adult and juvenile substance abuse centers
- Adult correctional institutions
- Juvenile detention facilities and training schools
- Adult local detention facilities
- Adult and juvenile work camps and community residential centers

### Residential

An occupancy that provides sleeping accommodations for purposes other than health care or detention and correctional. Residential occupancies are treated separately in the Code in the following groups:

- One- and Two-Family Dwelling Units
- Lodging or Rooming Houses
- Hotels & Dormitories
- Apartment Buildings

### Residential Board & Care

A building or portion thereof that is used for lodging and boarding of four or more residents, not related by blood or marriage to the owners or operators, for the purpose of providing personal care services.

### Mercantile

An occupancy used for the display and sale of merchandise.

Mercantile occupancies include the following:

- Auction rooms
- Department stores
- Drugstores
- Shopping centers
- Supermarkets

### Business

An occupancy used for the transaction of business other than mercantile.

Business occupancies include the following:

- Air traffic control towers (ATCT's)
- Dentists' offices
- City halls
- Doctors' offices
- College and university instructional buildings classrooms under 50 persons, and
- Town halls instructional laboratories
- Courthouses
- General offices
- Outpatient clinics, ambulatory

### Industrial

An occupancy in which products are manufactured or in which processing, assembling, mixing, packaging, finishing or decorating, or repair operations are conducted.

Industrial occupancies include the following:

- Dry cleaning plants
- Hangars (service/maintenance)
- Pumping stations
- Food processing plants
- Factories of all kinds
- Telephone exchanges
- Sawmills
- Refineries
- Power Plants
- Laundries
- Gas plants

### Storage

An occupancy used primarily for the storage or sheltering of goods, merchandise, products, vehicles, or animals.

Storage occupancies include the following:

- Barns
- Bulk oil storage
- Cold storage
- Freight terminals
- Stables
- Grain elevators
- Hangars (for storage only)
- Parking structures

### Day-Care

An occupancy in which four or more clients receive care, maintenance, and supervision, by other than their relatives or legal guardians, for less than 24 hours per day.

Day-care occupancies include the following:

- Child day-care occupancies
- Nursery schools
- Adult day-care occupancies except where part of a health care occupancy
- Day care homes
- Kindergarten classes that are incidental to a child day-care occupancy

### Multiple Occupancies

A building or structure in which two or more classes of occupancy exist.

A Mixed Occupancy is a multiple occupancy where the occupancies are intermingled.

A Separated Occupancy is a multiple occupancy where the occupancies are separated by fire resistance-rated assemblies.

### Hazard of Contents (6.2)

**Hazard of contents of any building or structure shall be classified as one of the following:**

#### Low Hazard

Contents are of such low combustibility that no self-propagating fire therein can occur.

#### Ordinary Hazard

Contents are likely to burn with moderate rapidity or to give off a considerable volume of smoke.

#### High Hazard

Contents are likely to burn with extreme rapidity or from which explosions are likely.

# Highlights of National Fire Protection Association (NFPA) 101® - Life Safety Code® 2006 & NFPA 5000™ - Building Construction & Safety Code 2006

Notes: In this Code Reference Guide, "fire protection system" means an approved sprinkler system, approved fire alarm system, or both. Numbers in brackets ( ) refer to applicable sections of the code publication.

## **Locks, Latches, and Alarm Devices** (NFPA 101®: 7.2.1.5, NFPA 5000™: 11.2.1.5.2)

Locks, if provided, shall not require the use of a key, tool, or special knowledge or effort for operation from the egress side...

- except as specifically allowed by the occupancy chapters
- exterior doors shall be permitted to have key-operated locks from the egress side as long as:
  - exception is permitted in the occupancy chapters for the specific occupancy, and
  - on or adjacent to the door there is a sign (THIS DOOR TO REMAIN OPEN WHEN THE BUILDING IS OCCUPIED), and
  - locking device is of a type that is readily distinguishable as locked, and
  - key is immediately available to any occupant inside the building when door is locked
- these provisions may be revoked by the AHJ for cause
- where permitted by the occupancy chapters, key operation shall be permitted, provided that the key can't be removed when the door is locked from the egress side

## **Stairwell Reentry** (NFPA 101®: 7.2.1.5.7, NFPA 5000™: 11.2.1.5.8.1)

Every door in a stair enclosure serving more than four stories shall meet one of the following criteria:

- re-entry from the stair enclosure to the interior of the building shall be provided,
- an automatic release actuated by the fire alarm system shall unlock all stair enclosure doors to provide reentry
- selected reentry - selected doors shall be permitted to have locking hardware, provided that
  - at least 2 levels are unlocked, there aren't more than 4 stories between unlocked floors, and
  - the top or next to the top floor is unlocked, signage on the stair side identifies unlocked doors, and
  - signage on the stair side of locked doors indicates the location of the nearest unlocked door in each direction

The following applications are not required to comply:

- existing installations as permitted in the occupancy chapters
- stairs serving a building permitted to have a single exit in accordance with the occupancy chapters
- stairs in health care occupancies where otherwise provided in the occupancy chapter
- stairs in detention and correctional occupancies where otherwise provided in the occupancy chapter

## **Stair to Roof** (NFPA 101®: 7.2.1.5.8, NFPA 5000™: 11.2.1.5.9)

If a stair enclosure allows access to the roof, the door to the roof either shall be kept locked or shall allow re-entry from the roof

## **Releasing Devices** (NFPA 101®: 7.2.1.5.9 - 7.2.1.5.11, NFPA 5000™: 11.2.1.5.10 - 11.2.1.5.12)

- latch or other fastening device on a door shall be provided with a releasing device having an obvious method of operation under all lighting conditions
- releasing mechanism (except existing installations) shall be located between 34" and 48" above the finished floor.  
Doors shall be operable with not more than 1 releasing operation
  - exception: egress doors from individual living units and guest rooms of Residential Occupancies may require 2 releasing operations, as long as no key is required for egress and both mechanisms are less than 48" A.F.F. (existing security devices complying with this exception may have three releasing operations - devices that are not automatic latching may be located up to 60" A.F.F.)
- each leaf of a pair in a means of egress shall have its own releasing device, and each device has to operate independently (can't require 1 device to be released before the other), except
  - where automatic flush bolts are used, the door leaf with the flush bolts shall have no doorknob or surface-mounted hardware - unlatching any leaf shall not require more than 1 operation
  - no additional locking device (padlock, hasp, chain, deadbolt, etc.) shall be installed on a door which requires panic hardware

**Delayed Egress Locks** (NFPA 101®: 7.2.1.6.1, NFPA 5000™: 11.2.1.6.1)

Approved, listed, delayed egress locks shall be permitted on doors serving low and ordinary hazard contents in buildings protected throughout by an approved, supervised automatic fire detection system or sprinkler system, where permitted by chapters 12-42, provided that:

- doors unlock upon actuation of the sprinkler system, any heat detector, or up to 2 smoke detectors, and
- doors unlock upon loss of power controlling the locking mechanism, and
- an irreversible process (such as pushing the door or touchpad) releases the lock within 15 (AHJ can approve a delay of up to 30 seconds) upon application to the release device (15 lbf for not more than 3 seconds), and
- initiation of the release process activates an audible signal in the vicinity of the door, and
- after release, locking shall be by manual means only, and
- signage on egress side of door (PUSH UNTIL ALARM SOUNDS. DOOR CAN BE OPENED IN 15 SECONDS)

**Access-Controlled Egress Doors** (NFPA 101®: 7.2.1.6.2, NFPA 5000™: 11.2.1.6.2)

Where permitted in the occupancy chapters, doors in the means of egress shall be permitted to have an approved entrance and egress access control system, provided that:

- one of the following shall be provided:
  - a sensor on the egress side unlocks the door upon detection of an occupant approaching the door, or
  - listed panic or fire exit hardware that, when operated, unlocks the door, and
- loss of power to the sensor unlocks the door, and loss of power to the lock unlocks the door, and
- manual release device adjacent to the door unlocks the door, must have signage (PUSH TO EXIT), and must result in direct interruption of power to the lock, and door remains unlocked for at least 30 seconds, and
- if the building has a fire protection system, actuation of the fire protection system automatically unlocks the door, and the door remains unlocked until the fire protection system is manually reset

**Panic Hardware** (NFPA 101®: 7.2.1.7, NFPA 5000™: 11.2.1.7)

- actuating portion of device must extend at least 1/2 the width of the door leaf
- device must be mounted between 34" and 48" above finished floor (A.F.F.) (30" to 48" for existing applications)
- door locations requiring panic hardware are listed within the individual occupancy chapters:
  - means of egress doors in Assembly, Day Care, and Educational Occupancies with an occupant load of 100 or more persons shall be permitted to have a latch or lock only if it is panic hardware
  - doors serving high hazard contents areas with occupant loads of more than five shall be permitted to have a latch or lock only if it is panic hardware
- required panic hardware (except as allowed for Detention & Correctional Occupancies), shall not be equipped with any locking device, set screw, or other arrangement that prevents the release of the latch when pressure is applied to the releasing device
- fire exit hardware may not be equipped with devices to hold the latch retracted unless the devices are listed and approved for such purposes

**Self-Closing Devices** (NFPA 101®: 7.2.1.8, NFPA 5000™: 11.2.1.8)

Doors designed to normally be kept closed in a means of egress shall be a self-closing door and shall not be secured in the open position, except:

- where allowed by NFPA 101®/5000 or the AHJ, doors can be automatic closing, if
  - upon release of the hold-open mechanism, the door becomes self-closing, and
  - door can be easily released manually, and
  - releasing mechanism is activated by the building fire protection system, and
  - upon loss of power to the hold-open device, the door becomes self-closing, and
  - release of one door in a stair enclosure results in closing of all doors in that stair

Note: A standard door closer with no hold-open mechanism is self-closing. A door with a closer and an electric or battery-operated hold-open mechanism actuated by the fire protection system is automatic-closing.

# Highlights of the International Code Council (ICC) International Building Code® 2006

Notes: In this Code Reference Guide, "fire protection system" means an approved sprinkler system, approved fire alarm system, or both. Numbers in brackets ( ) refer to applicable sections of the code publication.

## Power Operated Doors (1008.1.3.2)

- in power failure, doors must be capable of being opened manually, or closed where necessary to safeguard means of egress
- forces to operate manually must not exceed those specified in section 1008.1.2, except the force to set the door in motion shall not exceed 50 pounds, and door shall swing to full width of opening
- full-power-operated doors shall comply with Builders Hardware Manufacturers Association (BHMA) A156.10, power-assisted and low-energy operators shall comply with BHMA A156.19
- exceptions for group I-3, horizontal sliding doors complying with section 1008.1.3.3, and bi-parting doors

## Access-Controlled Egress Doors (1008.1.3.4)

Entrance doors and entrance doors to tenant spaces in groups A, B, E, M, R-1, or R-2 may be equipped with an approved entrance and egress access control system installed in accordance with all of the following:

- sensor on egress side must detect an occupant approaching the door - door must unlock by a signal from, or loss of power to the sensor, and
- loss of power to locking device must unlock the door, and
- door shall unlock by a readily-accessible manual unlocking device (push button) marked "Push to Exit", located 40 inches to 48 inches above the floor within 5' of the door, and manual unlocking device must interrupt power to the lock, independent of the access control system, door must unlock for 30 seconds, and
- fire alarm or sprinkler system must unlock the door until system is reset, and
- entrance doors in Groups A, B, E, and M shall not be secured from the egress side when the building is open to the general public

## Door Operations (1008.1.8)

- operating devices on accessible doors shall not require tight grasping, tight pinching, or twisting of the wrist to operate
- door handles, pulls, latches, locks, and other operating devices shall be installed 34" minimum and 48" maximum above the floor
  - locks used for security purposes and not used for normal operation are permitted at any height
  - Locks used on access doors protecting pools, spas, and hot tubs can have operable parts up to 54" above the finished floor.

## Locks and Latches (1008.1.8.3)

Locks and latches shall be permitted to prevent operation of doors in the following conditions:

- places of detention or restraint
- in Group A with an occupant load of 300 or less, Groups B, F, M., and S, and in churches, the main exterior door may have a key operated lock on the egress side as long as:
  - lock is a type which can be readily distinguishable as locked, and
  - on or adjacent to the door on the egress side there is a sign (THIS DOOR TO REMAIN UNLOCKED WHEN BUILDING IS OCCUPIED) in 1 inch high letters on a contrasting background, and
  - use of key-operated locking device may be revoked by the building official for due cause
- where automatic flush bolts are used, the door leaf equipped with automatic flush bolts shall not have a door knob or surface mounted hardware, and the unlatching of any leaf shall not require more than one operation
- in Group R, egress doors from individual dwelling units or sleeping units having an occupant load of 10 or less may have a night latch, dead bolt, or security chain - devices must be openable from the inside without the use of a key or tool

### Use Groups for the ICC International Building Code® (consult code for complete descriptions)

- A - Assembly
- B - Business
- E - Educational
- F - Factory
- H - High-Hazard
- I - Institutional
- M - Mercantile
- R - Residential
- S - Storage
- U - Utility & Miscellaneous

**Bolt Locks (Flush and Surface Bolts)** (1008.1.8.4)

Manually operated flush bolts and surface bolts are not permitted; exceptions: doors not required for egress in dwelling units or sleeping units, and doors to storage or equipment rooms

**Unlatching** (1008.1.8.5)

Unlatching any leaf shall not require more than one operation; exceptions: places of detention or restraint, where manual bolts are permitted by section 1008.1.8.4, doors with auto flush bolts and doors from individual dwelling units and guest rooms as permitted by section 1008.1.8.3

**Delayed Egress Locks** (1008.1.8.6)

delayed egress devices may be used in any occupancy except Group A, E, and H, in buildings equipped throughout with an automatic sprinkler or automatic smoke or heat detection system, as long as:

- upon actuation of the fire alarm or sprinkler system, there must be no delay, and
- there is no delay upon loss of power to the egress control device, and
- the device has the capability of being unlocked manually by a signal from the fire command center, and
- latch is released within 15 seconds when a force of 15 pounds maximum is applied for 1 second, device may only be rearmed manually; exception: code official may approve 30 second delay, and
- initiation of cycle shall activate audible alarm in vicinity of door, and
- sign with 1" high letters mounted on the door within 12" of the release device states "Push until alarm sounds. Door can be opened in 15 seconds.", and
- emergency lighting must be provided at the door

a building occupant shall not encounter more than 1 delay before entering an exit

**Stairway Doors** (1008.1.8.7)

Interior stairway means of egress doors shall be openable from both sides without the use of a key or special knowledge or effort.

Exceptions:

- stairway discharge doors shall be openable from the egress side and shall only be locked from the opposite side
- section 403.12 refers to high-rise buildings (over 75 feet in height) and states that stair doors which are locked on the stair side must unlock simultaneously without unlatching upon a signal from the fire command system, and that a telephone or other 2-way communication device connected to a constantly attended station must be provided at every fifth floor if the stair doors are locked
- in stairways serving not more than 4 stories, doors may be locked on the stair side, as long as they are not locked on the egress side provided they are openable from the egress side and capable of being unlocked simultaneously without unlatching upon a signal from the fire command system

**Panic and Fire Exit Hardware** (1008.1.9)

Doors equipped with latches in groups A or E and serving an occupant load greater than 50 or in groups H-1, H-2, H-3, H-5 regardless of occupant load shall have panic hardware

- actuating portion of device must extend at least 1/2 the width of the door leaf
- maximum force to unlatch is 15 pounds
- balanced doors with panic hardware must have push-pad type panics, and the pad shall not extend more than one-half the width of the door measured from the latch side
- Electrical rooms with equipment rated 1,200 amperes or more and over 6 feet wide that contain overcurrent devices, switching devices or control devices with exit access doors must be equipped with panic hardware and doors must swing in the direction of egress.

**Positive Pressure** (715.4.1)

Fire doors must be tested in accordance with NFPA 252 or UL10C; after 5 minutes into the NFPA 252 test, the neutral pressure level in the furnace shall be 40" or less above the sill

**Temperature Rise Doors** (715.4.4)

Fire doors in vertical exit enclosures and exit passageways shall have a max. transmitted temperature end point of not more than 450°F above ambient after 30 minutes of fire test exposure; exception: not required in buildings equipped throughout with an automatic sprinkler system

# Highlights of the International Code Council (ICC) International Building Code® 2003

Notes: In this Code Reference Guide, "fire protection system" means an approved sprinkler system, approved fire alarm system, or both. Numbers in brackets ( ) refer to applicable sections of the code publication.

## Power Operated Doors (1008.1.3.2)

- in power failure, doors must be capable of being opened manually, or closed where necessary to safeguard means of egress
- forces to operate manually must not exceed those specified in section 1008.1.2, except the force to set the door in motion shall not exceed 50 pounds, and door shall swing to full width of opening
- full-power-operated doors shall comply with Builders Hardware Manufacturers Association (BHMA) A156.10, power-assisted and low-energy operators shall comply with BHMA A156.19
- exceptions for group I-3, horizontal sliding doors complying with section 1008.1.3.3, and bi-parting doors

## Access-Controlled Egress Doors (1008.1.3.4)

Entrance doors and entrance doors to tenant spaces in groups A, B, E, M, R-1, or R-2 may be equipped with an approved entrance and egress access control system installed in accordance with all of the following:

- sensor on egress side must detect an occupant approaching the door - door must unlock by a signal from, or loss of power to the sensor, and
- loss of power to locking device must unlock the door, and
- door shall unlock by a readily-accessible manual unlocking device (push button) marked "Push to Exit", located 40 inches to 48 inches above the floor within 5' of the door, and manual unlocking device must interrupt power to the lock, independent of the access control system, door must unlock for 30 seconds, and
- fire alarm or sprinkler system must unlock the door until system is reset, and
- entrance doors in Groups A, B, E, and M shall not be secured from the egress side when the building is open to the general public

## Door Operations (1008.1.8)

- operating devices on accessible doors shall not require tight grasping, tight pinching, or twisting of the wrist to operate
- door handles, pulls, latches, locks, and other operating devices shall be installed 34" minimum and 48" maximum above the floor
  - locks used for security purposes and not used for normal operation are permitted at any height
  - Locks used on access doors protecting pools, spas, and hot tubs can have operable parts up to 54" above the finished floor.

## Locks and Latches (1008.1.8.3)

Locks and latches shall be permitted to prevent operation of doors in the following conditions:

- places of detention or restraint
- in Group A with an occupant load of 300 or less, Groups B, F, M., and S, and in churches, the main exterior door may have a key operated lock on the egress side as long as:
  - lock is a type which can be readily distinguishable as locked, and
  - on or adjacent to the door on the egress side there is a sign (THIS DOOR TO REMAIN UNLOCKED WHEN BUILDING IS OCCUPIED) in 1 inch high letters on a contrasting background, and
  - use of key-operated locking device may be revoked by the building official for due cause
- where automatic flush bolts are used, the door leaf equipped with automatic flush bolts shall not have a door knob or surface mounted hardware, and the unlatching of any leaf shall not require more than one operation
- in Group R, egress doors from individual dwelling units or sleeping units having an occupant load of 10 or less may have a night latch, dead bolt, or security chain - devices must be openable from the inside without the use of a key or tool

### Use Groups for the ICC International Building Code® (consult code for complete descriptions)

- A - Assembly
- B - Business
- E - Educational
- F - Factory
- H - High-Hazard
- I - Institutional
- M - Mercantile
- R - Residential
- S - Storage
- U - Utility & Miscellaneous

**Bolt Locks (Flush and Surface Bolts)** (1008.1.8.4)

Manually operated flush bolts and surface bolts are not permitted; exceptions: doors not required for egress in dwelling units or sleeping units, and doors to storage or equipment rooms

**Unlatching** (1008.1.8.5)

Unlatching any leaf shall not require more than one operation; exceptions: places of detention or restraint, where manual bolts are permitted by section 1008.1.8.4, doors with auto flush bolts and doors from individual dwelling units and guest rooms as permitted by section 1008.1.8.3

**Delayed Egress Locks** (1008.1.8.6)

delayed egress devices may be used in any occupancy except Group A, E, and H, in buildings equipped throughout with an automatic sprinkler or automatic smoke or heat detection system, as long as:

- upon actuation of the fire alarm or sprinkler system, there must be no delay, and
- there is no delay upon loss of power to the egress control device, and
- the device has the capability of being unlocked manually by a signal from the fire command center, and
- latch is released within 15 seconds when a force of 15 pounds maximum is applied for 1 second, device may only be rearmed manually; exception: code official may approve 30 second delay, and
- initiation of cycle shall activate audible alarm in vicinity of door, and
- sign with 1" high letters mounted on the door within 12" of the release device states "Push until alarm sounds. Door can be opened in 15 seconds.", and
- emergency lighting must be provided at the door

a building occupant shall not encounter more than 1 delay before entering an exit

**Stairway Doors** (1008.1.8.7)

Interior stairway means of egress doors shall be openable from both sides without the use of a key or special knowledge or effort.

Exceptions:

- stairway discharge doors shall be openable from the egress side and shall only be locked from the opposite side
- section 403.12 refers to high-rise buildings (over 75 feet in height) and states that stair doors which are locked on the stair side must unlock simultaneously without unlatching upon a signal from the fire command system, and that a telephone or other 2-way communication device connected to a constantly attended station must be provided at every fifth floor if the stair doors are locked
- in stairways serving not more than 4 stories, doors may be locked on the stair side, as long as they are not locked on the egress side provided they are openable from the egress side and capable of being unlocked simultaneously without unlatching upon a signal from the fire command system

**Panic and Fire Exit Hardware** (1008.1.9)

Doors equipped with latches in groups A or E and serving an occupant load greater than 100 or in groups H-1, H-2, H-3, H-5 regardless of occupant load shall have panic hardware

- actuating portion of device must extend at least 1/2 the width of the door leaf
- maximum force to unlatch is 15 pounds
- balanced doors with panic hardware must have push-pad type panics, and the pad shall not extend more than one-half the width of the door measured from the latch side
- Electrical rooms with equipment rated 1,200 amperes or more and over 6 feet wide that contain overcurrent devices, switching devices or control devices with exit access doors must be equipped with panic hardware and doors must swing in the direction of egress.

**Positive Pressure** (715.4.1)

Fire doors must be tested in accordance with NFPA 252 or UL10C; after 5 minutes into the NFPA 252 test, the neutral pressure level in the furnace shall be 40" or less above the sill

**Temperature Rise Doors** (715.4.4)

Fire doors in vertical exit enclosures and exit passageways shall have a max. transmitted temperature end point of not more than 450°F above ambient after 30 minutes of fire test exposure; exception: not required in buildings equipped throughout with an automatic sprinkler system

# Highlights of the Building Official & Code Administrators (BOCA) National Building Code 1999

Notes: In this Code Reference Guide, "fire protection system" means an approved sprinkler system, approved fire alarm system, or both. Numbers in brackets ( ) refer to applicable sections of the code publication.

## Door Hardware (1017.4)

- operating devices shall be between 34" and 48" max. above the floor
- operating devices shall be operable with one hand and shall not require tight grasping, tight pinching or twisting of the wrist to operate
- means of egress doors shall be side-swinging type and shall swing in the direction of egress where serving an occupant load of 50 or more persons or where serving a high-hazard occupancy
- opening force for interior swinging doors without closers shall not exceed 5 pounds, or 15 pounds for all other swinging, sliding, and folding doors, latch must release with 15-pound force, 30-pound force shall set door in motion, and 15-pound force shall swing door to full-open position (forces applied to latch side)
- refer to code for exceptions

## Locks and Latches (1017.4.1)

All means of egress doors shall be readily openable from the egress side without the use of a key or special knowledge or effort, exceptions:

- key operation shall be permitted from a dwelling unit, provided the key cannot be removed from the lock when the door is locked
- in use group I-2, patient rooms may be locked on the corridor side, but shall not restrict egress from the patient room except for mental health facilities
- in use group I-3, doors from an area of refuge to the exterior may be locked - the keys shall be available at all times and the locks shall be operable from both sides of the door (see 410.4 for more information)
- in use group R, egress doors from individual dwelling units and guest rooms having an occupant load of 10 or less may have a night latch, dead bolt, or security chain - devices must be openable from the inside without the use of a key or tool, and are mounted no more than 48" above the floor
- special locking arrangements conforming to section 1017.4.1.2 or 1017.4.1.3 (see next page)
- in use groups B, F, M, and S, the main exterior egress door may have a key-operated lock on the egress side if:
  - lock is a type which can be readily distinguishable as locked, and
  - on or adjacent to the door on the egress side there is a sign (THIS DOOR TO REMAIN OPEN WHEN THE BUILDING IS OCCUPIED) in 1 inch high letters on a contrasting background, and
  - opening is a single or pair of doors which swing freely when unlocked (push/pull hardware)
- access-controlled egress doors conforming to section 1017.4.5 (see next page)

## Flush and Surface Bolts (1017.4.1.1)

- manually operated edge or surface-mounted flush bolts and surface bolts are prohibited
- where automatic flush bolts are used, the door leaf equipped with automatic flush bolts shall not have a door knob or surface mounted hardware
- the unlatching of any leaf shall not require more than one operation

## Stairwell Reentry (1014.11.3)

Interior stairway means of egress doors shall be openable from both sides without the use of a key or special knowledge or effort, exceptions:

- stairway discharge doors shall be openable from the egress side and may be locked on the opposite side
- section 403.10 refers to high-rise buildings (over 75 feet in height) and states that stair doors which are locked on the stair side must unlock simultaneously without unlatching upon a signal from the fire command system, and that a telephone or other 2-way communication device connected to a constantly attended station must be provided at every fifth floor if the stair doors are locked
- there is currently no exception for buildings less than 75 feet, but the BOCA Commentary states that the requirements of 403.10 (above) would be acceptable for a building that is not a high-rise building

### Use Groups for the BOCA National Building Code® (consult code for complete descriptions)

- A - Assembly
- B - Business
- E - Educational
- F - Factory
- H - High-Hazard
- I - Institutional
- M - Mercantile
- R - Residential
- S - Storage
- U - Utility & Miscellaneous

### **Special Locking Arrangements (1017.4.1.2)**

- in buildings equipped throughout with an automatic sprinkler or fire detection system, egress doors in use Groups B, E, F, I, M, S, or R (note that A is not included) may be equipped with delayed egress devices which release in accordance with the following:
  - upon actuation of the fire alarm or sprinkler system, there must be no delay, and
  - there must be no delay upon loss of power to the egress control device or loss of power to the building, and
  - device has capability of being unlocked manually by a signal from an emergency control station, and
  - latch is released within 15 seconds when a force of 15 pounds maximum is applied for 1 second, device is not rearmed until door has opened, closed, and stays closed for at least 30 seconds, reopening the door will restart the 30 second relocking cycle, time delay and relock time are not field adjustable (code official may approve 30 second delay and 45 second relock time), and
  - initiation of cycle shall activate audible alarm in vicinity of door, and
  - sign with 1" high letters mounted on the door within 12" of the release device states "Push until alarm sounds."
  - Door can be opened in 15 seconds."
- a building occupant shall not encounter more than 1 delay before entering an exit

### **Panic Hardware (1017.4.2)**

Doors equipped with latches in use groups A and E and serving an occupant load greater than 100 shall have panic hardware

- actuating portion of device must extend at least 1/2 the width of the door leaf
- device must be mounted between 30" and 44" A.F.F.
- no more than 15 pounds of force required to release latch
- fire doors must have fire exit hardware

### **Power Operated Doors (1017.4.3)**

- in power failure, must be capable of being opened manually, or closed where necessary to safeguard means of egress
- forces to operate manually must not exceed those specified in section 1017.4, except the force to set the door in motion shall not exceed 50 pounds, and door shall swing to full width of opening
- exceptions for use group I-3 and for horizontal sliding doors complying with section 1017.4.4

### **Access-Controlled Egress Doors (1017.4.5)**

Entrance doors and entrance doors to tenant spaces in use groups A, B, E, M, R-1, or R-2 may be equipped with an approved entrance and egress access control system installed in accordance with the following:

- sensor on egress side must detect an occupant approaching the door - door must unlock by a signal from or loss of power to the sensor, and loss of power to the locking device must unlock the door, and
- door shall unlock by a manual unlocking device (push button) located 40 inches to 48 inches above the floor within 5' of the door, signage is required, and manual unlocking device must interrupt power to the lock, independent of the access control system, door must unlock for 30 seconds, and
- fire alarm or sprinkler system must unlock the door until system is reset, and
- entrance doors in use groups A, B, E, and M shall not be secured from the egress side when the building is open to the general public

### **Temperature Rise Doors (717.1.2)**

Fire doors in exit enclosures shall have a max. transmitted temperature end point of not more than 450°F above ambient after 30 minutes of fire test exposure

- exception: buildings equipped throughout with an automatic sprinkler system

# Highlights of the Southern Building Code Congress International (SBCCI) Standard Building Code 1999

Notes: In this Code Reference Guide, "fire protection system" means an approved sprinkler system, approved fire alarm system, or both. Numbers in brackets ( ) refer to applicable sections of the code publication.

## Doors - General (1012.1)

- clear opening width for egress doors used as exit doors - 32" minimum for most occupancies, 36" for Group I Unrestrained, 44" in areas requiring movement of beds in Group I Unrestrained (refer to 1024.1.2.1 for specific information)
- maximum leaf width - 48"
- egress doors in the exit access - 32" clear minimum
- must be side-swinging type, and shall swing in the direction of egress when serving an occupant load of 50 or more, or when serving a high hazard occupancy (all egress doors in Group H per 1023.1), maximum force of 15 lb. to release latch, 30 lb. to set the door in motion, 15 lb to swing door fully open
  - exceptions for specific occupancies, revolving doors, and horizontal sliding doors noted
  - some exceptions for specific occupancy types include: office areas with an occupant load of 10 or less (1020.2), factory areas with an occupant load of 10 or less (1022.2), certain dwelling unit doors (1026.3), automobile parking garages and storage areas with an occupant load of 10 or less (1027.3)
- thresholds - 3/4" high maximum for exterior sliding doors serving dwelling units, 1/2" high maximum for other doors, raised thresholds and changes in level of more than 1/4" require a bevel with a slope of 1:2 maximum (exception - exterior doors not on an accessible route)
- operating hardware must operate with one hand and require no tight grasping, tight pinching, or twisting of the wrist (exceptions - doors serving a single dwelling unit not required to be accessible, doors within Type B dwelling units)
- required exit doors must be openable from the inside without a key, tool, special knowledge, or effort; manual flush or surface bolts are prohibited; all hardware must be direct-acting requiring no more than 1 operation
- double cylinder deadbolts are prohibited on required means of egress doors unless the key cannot be removed when the door is locked from the inside
- operating hardware mounting height - 34" minimum, 48" maximum (exception - locks used for security purposes and not used for normal operation may be mounted at any height)

## Power Operated Doors (1012.2)

- must be able to be manually opened in a power failure, with same requirements as manual doors
- sliding doors must have an emergency swing feature (exception for horizontal sliders conforming with 1012.4)
- power operated doors must comply with ANSI/BHMA A156.10

## Special Locking Arrangements (1012.6)

- not allowed in Group A (Assembly) occupancies
- building must be protected throughout by a fire protection system
- locking device must be approved and listed, and shall:
  - unlock upon activation of the fire protection system, and/or unlock upon loss of power controlling the lock, and
  - initiate an irreversible process which will unlock the door within 15 seconds when a force of not more than 15 lbs is applied to the door or releasing device, device will not relock until the door has been opened, upon initiation of irreversible process a signal in the vicinity of the door must indicate that the system is functional
- exception - standby power (1012.6.1, exception 1)
  - independent standby power is acceptable if the fire protection system has precedence over the standby power and unlocks the door,
  - in a power outage, the door may remain locked until the detection systems operate, as long as the power outage does not disable the detection systems
  - if any detection systems are disabled, standby power controlling the locking devices will be interrupted
  - exception - time delay - building official may approve a 30-second delay if reasonable life safety is assured
- signage is required on the door stating "PUSH. THIS DOOR WILL OPEN IN 15 SECONDS. ALARM WILL SOUND." - letters must be at least 1" high
- emergency lighting must be provided at the door

### Use Groups (consult code for complete descriptions)

- A - Assembly
- B - Business
- E - Educational
- F - Factory
- H - High-Hazard
- I - Institutional
- M - Mercantile
- R - Residential
- S - Storage

### **Access-Controlled Egress Doors (1012.7)**

Entrance doors in a means of egress and entrance doors to tenant spaces in Group B, M, R1 or R2 buildings may be equipped with an approved entrance and egress access control system which complies with the following:

- an approved listed releasing sensor/device, mechanical or electrical, must be provided on the egress side to detect an occupant attempting to exit, doors shall unlock by a signal from or loss of power to releasing device
- loss of power to the locking hardware must automatically unlock the doors
- manual unlocking device required for emergency unlocking purposes only
  - manual unlocking device must be located 40" to 48" vertically above the floor and within 5' of the doors
  - ready access to manual unlocking device must be provided, and signage is required
  - operation of device shall result in direct interruption of power to the lock, independent of the access control system electronics
  - activation of device shall unlock doors for 30 seconds minimum
- activation of the fire protection system (if the building has one) shall unlock the doors, doors to remain unlocked until the fire protection system is reset
- entrance doors in Groups B or M shall not be secured from the egress side when the building is open to the general public
- entrance doors in buildings having a mechanical means of egress in conjunction with an electric strike shall be latched when not energized
- independent standby power may be used on doors which provide immediate egress upon a signal from a listed releasing sensor/device and a signal from the fire protection system (if the building has one), as described in 1012.6.1 exception 1 (Special Locking Arrangements)

### **Special Egress Requirements by Occupancy (1019 - 1027)**

- Key-Operated Locks - for main exterior exit doors on Group A-2 with an occupancy of 300 or less (1019.7.1), main exterior exit doors in Group B (1020.3), Group F (1022.3), Group M (1025.2), and Group S (1027.4):
  - key locking devices may be used on the egress side if:
    - readily visible durable sign on or adjacent to the door states "THIS EXIT TO REMAIN UNLOCKED WHEN THIS BUILDING IS OCCUPIED" - 1" letters on a contrasting background
    - locking device must be readily distinguishable as locked
    - main exit door is a single door or one pair of doors
    - when unlocked, the door or both leaves of the pair must be free-swinging
    - code official may revoke the use of a key locking device for due cause
- Panic Hardware - means of egress doors from an area of a Group A occupancy (1019.7.2) and means of egress doors from an area of a Group E occupancy with an occupant load of 100 or more
  - may have a latch or lock only if it is panic hardware or fire exit hardware, which releases when a force of no more than 15 lb. is applied in the direction of exit travel
  - releasing devices may be bars or panels extending at least half the width of the door, mounted between 30" and 44" above finished floor
  - panic hardware used on a labeled fire door must be labeled as fire exit hardware
  - panic hardware used on balanced doors must be the pushpad type and the pad shall not extend more than 1/2 the width of the door measured from the latch side
- Group I Locks (1024.1.3) - patient rooms or tenant space egress doors must not be lockable except in places of restraint or detention
- Group I Restrained - refer to section 1024.2.8 and 1024.2.9 for several exceptions
- Dwelling Unit Locks (1026.4) - night latch, deadbolt, or security device is acceptable on exit doors from dwelling units and hotel guest rooms if devices are openable from the inside without a key, tool, special knowledge or effort, and the device is mounted no more than 48" above finished floor

# Highlights of the International Conference of Building Officials (ICBO) Uniform Building Code™ 1997

Notes: In this Code Reference Guide, "fire protection system" means an approved sprinkler system, approved fire alarm system, or both. Numbers in brackets ( ) refer to applicable sections of the code publication.

## Doors - General (1003.3.1.1)

- the term "exit door" means all of the doors along the path of exit travel anywhere in a means of egress system, exit doors shall comply with this section
- exit doors shall be readily distinguishable and recognizable, mirrors, curtains, drapes, decorations or similar materials may not be used to conceal exit doors

## Special Doors (1003.3.1.2)

- revolving, sliding, and overhead doors serving 10 or more occupants shall not be used as required exit doors (exceptions for certain revolving and horizontal sliding doors)
- power operated doors complying with Uniform Building Code (UBC) 10-1 may be used for egress (specific requirements for guide rails included)

## Width and Height (1003.3.1.3, 4)

- required exit doors serving an occupant load of 10 or more - minimum of 3' nominal width, 6'-8" nominal height, 32" clear width minimum, Group I occupancies - doors in areas serving bed or litter patients - 44" wide minimum (1007.5.1)
- buildings occupied by humans must have at least one exterior exit door that complies with these requirements
- single leaf of an exit door serving 10 or more occupants - 48" wide maximum

## Swing and Opening Force (1003.3.1.5)

- exit doors serving 10 or more occupants - pivoted, balanced, or side-hinged swinging type
- shall swing in the direction of exit travel where the area served has an occupant load of 50 or more; Group H exit and exit-access doors must swing in the direction of exit travel regardless of occupant load (1007.4.4); Group I required exterior exit doors shall open in the direction of exit travel regardless of occupant load (1007.5.5); refrigeration machinery rooms - doors shall swing in the direction of exit travel, regardless of the occupant load served, and shall be tight-fitting and self-closing (1007.7.2.3)
- opening force of 30 pounds applied to the latch side shall swing door to the fully open position (references to more information included, and exceptions for detention, dwelling units, and special doors)
- double-acting doors - not acceptable as exit doors if the occupant load served by the door is over 100, if the door is part of a fire or smoke- and draft-control assembly, or if panic hardware is required; double-acting doors require view panels of at least 200 square inches

## Type of Latch or Lock (1003.3.1.8)

- exit doors shall be openable from the inside without the use of a key or special knowledge or effort
- exception - key-operated locks
  - Groups A, Division 3; B; F; M; S; and in all churches, key-locking hardware may be used on the main exit where the main exit is a single door or pair of doors
  - readily visible durable sign on or adjacent to the door states "THIS DOOR MUST REMAIN UNLOCKED DURING BUSINESS HOURS" in letters at least 1" high on a contrasting background
  - when unlocked, single door or both leaves of pair must swing freely without operation of a latching device building official may revoke this exception for due cause
  - exception - dwelling units - exit doors from individual dwelling units; Group R, Division 3 congregate residences; and guest rooms of Group R occupancies with an occupant load of 10 or less may have a night latch, dead bolt, or security chain, if devices are openable from the inside without a key or tool and mounted 48" maximum A.F.F.
- manually operated edge- or surface-mounted flush bolts and surface bolts or any other device that may be used to restrain the door other than by operation of the locking device may not be used
- where pairs of exit doors have automatic flush bolts, the inactive leaf shall not have a doorknob or surface-mounted hardware
- the unlatching of any leaf shall not require more than 1 operation; exceptions - 1) Group R, Division 3 occupancies, 2) where a pair of doors serving a room not normally occupied is needed for the movement of equipment, manually operated edge- or surface-mounted bolts may be used

### Use Groups (consult code for complete descriptions)

- A - Assembly
- B - Business
- E - Educational
- F - Factory and Industrial
- H - High-Hazard
- I - Institutional
- M - Mercantile
- R - Residential
- S - Storage
- U - Utility

### **Panic Hardware (1003.3.1.9)**

- shall comply with UBC standard 10-4, shall be mounted between 30" and 44" A.F.F, and shall operate with a force of not more than 15 pounds in the direction of exit travel
- panic hardware used on pivoted or balanced doors shall be push-pad type, pad shall not extend more than 1/2 the width of the door measured from the latch side
- exit and exit-access doors serving Group A occupancies shall not be provided with a latch or lock unless it is panic hardware (exceptions for key-locking devices on Group A, Division 3 occupancies and all churches, and gates surrounding stadiums) (1007.2.5)
- exit and exit-access doors serving Group E occupancies with an occupant load of 50 or more and from corridors shall not be provided with a latch or lock unless it is panic hardware (1007.3.10)
- exit and exit-access doors from rooms in Group H, Divisions 1, 2, 3, 6, and 7 occupancies shall not be provided with a latch or lock unless it is panic hardware (1007.4.5)
- exit and exit-access doors serving an area in Group I with an occupant load of 50 or more shall not be provided with a latch or lock unless it is panic hardware - patient room doors shall be readily openable without the use of keys (1007.5.8), (exceptions for locks on patient rooms in Group 1, Divisions 1.1 and 3)

### **Special Egress-Control Devices (1003.3.1.10)**

- when approved by the building official, exit doors in Group B; F; I, Division 2; M; R, Division 1 congregate residences serving as group-care facilities; and S occupancies may be equipped with approved listed special egress-control devices of the time-delay type, if the building is protected throughout by an approved automatic sprinkler system and an approved automatic smoke-detection system
- egress-control device shall deactivate upon activation of either the sprinkler system or smoke-detection system
- egress control device shall deactivate upon loss of power to any of the following:
  - egress-control device
  - smoke-detection system
  - means of egress illumination required by Section 1003.2.9
- device shall be capable of being deactivated by a signal from a switch located in an approved location
- irreversible process to deactivate the egress-control device shall be initiated when a force of not more than 15 lbs is applied for 2 seconds to the panic bar or other door-latching hardware - device shall deactivate within 15 seconds, time delay shall not be field adjustable
- actuation of panic bar or door-latching hardware shall activate an audible signal at the door
- unlatching shall not require more than 1 operation
- signage on the door above and within 12" of the panic bar or other door-latching hardware states, "KEEP PUSHING. THIS DOOR WILL OPEN IN 15 SECONDS. ALARM WILL SOUND."
  - sign lettering at least 1" high with a stroke of at least 1/8"
- relocking of the egress-control device shall be by manual means only at the door

**Safety Glazing Identification (1003.3.1.11)** - glass doors shall conform to the requirements of Section 2406

For information on fire-ratings of doors and requirements for the "positive pressure" testing of fire doors, refer to sections 1004.3.4.3.2.1 (doors in the exit access), 1005.3.3.5 (openings and penetrations in the exit) and UBC Standard 7-2.

Note: The ICBO Uniform Building Code™ does not contain any reference to "Access-Controlled Egress Doors" or specific requirements for doors equipped with electromagnetic locks.

# Highlights of the National Building Code of Canada 2005

Notes: In this Code Reference Guide, "fire protection system" means an approved sprinkler system, approved fire alarm system, or both. Numbers in brackets ( ) refer to applicable sections of the code publication.

## Door Swing (3.3.1.11)

- except where sliding doors are permitted by section 3.3.1.12, doors opening into a corridor or other facility providing access to exit access shall swing on a vertical axis, and if the occupant load is 60 or more or if serving a high hazard industrial occupancy, the door shall swing in the direction of travel to the exit
- every door that divides a corridor that is not wholly contained within a suite shall swing on a vertical axis in the direction of travel to the exit
- if a pair in a corridor provides access to exit in both directions, The doors shall swing in opposite directions, with the door on the right hand side swinging in the direction of travel to the exit
- swing-type doors from service rooms containing incinerators or boilers shall swing outward from the room except if the door opens onto a corridor or any room used for Assembly occupancy (3.6.2.6)
- refer to section 3.4.6.11 for swing requirements for exit doors

## Doors and Door Hardware (3.3.1.13)

- a door that opens into or is located within a public corridor and provides access to an exit shall provide a clear opening of 800mm minimum for a single door or active leaf of a pair (1050mm minimum for doors required to accommodate moving patients in beds per 3.3.3.4)
- exit access doors shall be readily openable in the direction of exit travel, requiring no keys, special devices, or specialized knowledge (exception for contained use area or impeded egress zone)
- exit access doors shall be operable with one hand and one releasing operation (exception for dwelling unit/suite)
- dwelling unit doors may have on additional releasing operation, with no keys, special devices or knowledge
- door release hardware must be installed 1200mm maximum above the finished floor
- except for hotels and motels, doors opening onto a public exit access corridor must not relock automatically (3.3.4.5)

## Door Swing - Exits (3.4.6.11)

- except where sliding doors are permitted by section 3.4.6.13, every exit door shall open in the direction of exit travel and swing on a vertical axis

## Self-Closing Devices - Exits (3.4.6.12)

- exit doors normally required to be kept closed shall be self-closing and shall not be secured in the open position except as allowed by section 3.1.8.12(1)

## Door Release Hardware (3.4.6.15)

- locking, latching, and other fastening devices on the principal entrance door and all exit doors shall permit the door to be readily opened from the egress side with one operation and without the use of keys, special devices, or specialized knowledge (exceptions for contained use area, impeded egress zone, electromagnetic locks and security doors on banks and mercantile facilities)
- if the door is equipped with a latch, a device which will release the latch and allow the door to swing wide open when a force of not more than 90 N is applied in the direction of travel to the exit shall be installed on:
  - every exit door from a floor area of an Assembly Occupancy with an occupant load of more than 100,
  - every door leading to an exit lobby from an exit stair shaft and every exterior door leading from an exit stair shaft in a building having an occupant load of more than 100,
  - every exit door from a floor area containing a High Hazard Industrial occupancy
- except where required by section 3.8.3.3 (Barrier-Free Doorways and Doors), every exit door shall open with a force of not more than 90 N after the latch is released, force applied at the releasing device
- electromagnetic locks without latches, pins, or other devices to keep the door closed may be installed on exit doors except doors leading directly from high hazard industrial occupancies, provided:
  - building is equipped with a fire alarm system, and
  - locking device and all similar devices in the exit access leading to the exit unlock upon fire alarm, and
  - locking device releases upon loss of power to the lock and associated auxiliary controls, and

( continued on next page )

### Use Groups (consult code for complete descriptions)

- A - Assembly
- B - Care or Detention
- C - Residential
- D - Business and Personal Service
- E - Mercantile
- F - Industrial

# Highlights of the National Building Code of Canada 2005

## **Door Release Hardware - Exits (3.4.6.15) - continued**

- device releases upon operation of a manually operated switch accessible only to authorized personnel, and
  - a force of 90 N applied to the door opening hardware initiates an irreversible process that releases the locking device within 15 seconds and device shall not relock until the door has been opened, and
  - upon release, the locking device must be manually reset by the switch referred to above, and
  - if more than one locking device of this type is used in a building, the switch must release and reset all locking devices simultaneously (appendix), and
  - a legible sign must be permanently mounted on the exit door to indicate that the locking device will release 15 seconds after the application of force to the door opening hardware
- operating hardware for the doors to in this section shall be installed 1200 mm maximum above the finished floor

## **Security for Banks and Mercantile Floor Areas (3.4.6.16)**

- requirements of section 3.4.6.15 may be waived for bank and mercantile occupancies due to security concerns
- buildings must be sprinklered throughout
- consult section 3.4.6.16 for specific requirements

## **Emergency Access to Floor Areas (3.4.6.17)**

In a building more than 6 stories high,

- doors providing access to floor areas from exit stairs shall not have locking devices to prevent access to the floor area from which the travel distance up or down to an unlocked door is more than 2 stories
- doors that provide access to the floor area (as required above) shall have signage on the stair side to indicate that they are openable from the stair side
- a master key for all locked doors in a stairwell shall be provided in a designated location accessible to fire-fighters, or the locked door shall have a wire glass panel not less than 0.0645 m<sup>2</sup> in area and located not more than 300mm from the door opening hardware
- if access to floor areas through unlocked doors is required by this section, an occupant entering the floor area must have access, through unlocked doors within the floor area, to at least one other exit

## **Barrier-Free Doorways and Doors (3.8.3.3)**

- every doorway in a barrier-free path of travel shall have a clear width of at least 800 mm when the door is in the open position (measured from the face of the door at 90 degrees to the outside edge of the frame stop, the projection of exit devices are taken into account - appendix)
- the doorway of at least one bathroom within a residential suite must have a clear width of at least 800mm when the door is in the open position
- door operating devices shall not require tight grasping or twisting of the wrist to operate
- thresholds shall be a maximum of 13 mm above the floor surface and shall be beveled
- doors that provide a barrier-free path of travel at an entrance referred to in Article 3.8.1.2 shall be equipped with a power operator in a hotel, a building of Group B, Division 2 major occupancy, and a building of Group A, D, or E major occupancy more than 500 m<sup>2</sup> in building area (exception - individual suite having an area less than 500 m<sup>2</sup> in a building having only suites of Assembly Occupancy, Business and Personal Services Occupancy, or Mercantile Occupancy if the suite is completely separated from the remainder of the building so that there is no access to the remainder of the building)
- door closers used in a barrier-free path of travel shall require a maximum force applied at the handle, push plate, or latch releasing device of no more than 38 N to operate an exterior door and 22 N to operate an interior door (exception - entrance to a dwelling unit, or where greater forces are required to close the door against prevailing difference in air pressure)
- door closers used on interior doors in a barrier-free path of travel shall have a closing period of not less than 3 seconds from the open position of 70 degrees to a point 75mm from the closed position, measured from the leading edge of the latch side of the door (exception - dwelling unit entrance doors), delayed action not required (appendix)
- only the active leaf in a multiple leaf door in a barrier free path of travel need to conform to the requirements

# Highlights of NFPA 80 – Standard for Fire Doors and Other Opening Protectives 2007

Note: Numbers in brackets () refer to applicable sections of the publication.

An asterisk following a number indicates the presence of explanatory material within the Annex of the publication.

## Equivalency (1.4)

- The Standard does not prohibit the development of new products that meet the intent of the requirements – it is the responsibility of the manufacturer to provide enough information to allow the AHJ to make a determination.

## Job-Site Hardware Preparation (4.1.3)

- Job-Site prep of surface applied hardware and function holes, maximum 1" diameter holes is permitted.
- Maximum 3/4" undercut for wood and composite doors allowed.
- Any preparations other than noted above must be done under label service.
- Plant-ons are allowed per the manufacturer's listing.

## Signage (4.1.4)

- Signage shall not exceed 5% of the area of the face of the door.

## Listed and Labeled Products (4.2)

- Listed items are required to bear a label
- Labels shall be applied in locations that are readily visible after installation
- Generic items such as hinges are not labeled but must comply with specifications

## Classification and Types of Doors (4.3)

- Swinging fire doors are permitted to be supplied separately with individually labeled frames and hardware
- Fire doors used with fire exit hardware shall be specifically labeled as such. Label shall address necessary reinforcements and the assembly shall have been tested for egress panic load requirements
- AHJ shall be consulted for oversized doors

## Glazing Material in Fire Doors (4.4)

- Only labeled fire resistance rated or fire protection rated glazing material and labeled lite kits may be used, when permitted by the door listing
- Allowable size of light depends on type of glazing and specific listings.
- Rule of thumb –
  - 1/2 and 1/3 hour rated – limited to maximum area tested (rule of thumb – 1296 square inches per door leaf)
  - 3/4 hour rated – 1296 square inches per door leaf
  - No dimension larger than 54", unless otherwise tested
  - 1 hour, 1-1/2 hour rated – limited to the maximum area tested (100 square inches in Temperature Rise Doors)
  - 3 hour rated – 100 square inches

## Classification of Hardware for Fire Doors (4.6.3.2)

- Builders hardware shall not be required to be shipped from the factory with the fire doors

## Sills (4.8.2)

- Noncombustible floors do not require special sills
- Combustible flooring is not permitted to extend through the door opening without the protection of non-combustible sills, 1/3 and 1/2 hour rated door openings are exempt
- Noncombustible sills shall be a minimum 4" wide, and shall extend from the face of the frame on the door side into the frame

## Lintels (4.8.3)

- Lintels shall be brick, steel, reinforced concrete, or concrete/masonry arches
- The AHJ can allow other types of lintels

## Undercuts (4.8.4)

- Maximum permitted undercut is 3/4"

## Inspections (5.2\*)

**5.2.1\*** Fire door assemblies shall be inspected and tested not less than annually, and a written record of the inspection shall be signed and kept for inspection by the AHJ.

## 5.2.2\* Performance-Based Option.

**5.2.2.1** As an alternate means of compliance with 5.2.1, subject to the AHJ, fire door assemblies shall be permitted to be inspected, tested, and maintained under a written performance-based program.

**5.2.2.2** Goals established under a performance-based program shall provide assurance that the fire door assembly will perform its intended function when exposed to fire conditions.

**5.2.2.3** Technical justification for inspection, testing, and maintenance intervals shall be documented.

**5.2.2.4** The performance-based option shall include historical data acceptable to the AHJ.

**5.2.4.1** Fire door assemblies shall be visually inspected from both sides to assess the overall condition of door assembly.

**5.2.4.2** As a minimum, the following items shall be verified:

- (1) No open holes or breaks exist in surfaces of either the door or frame.
- (2) Glazing, vision light frames, and glazing beads are intact and securely fastened in place, if so equipped.
- (3) The door, frame, hinges, hardware, and noncombustible threshold are secured, aligned, and in working order with no visible signs of damage.
- (4) No parts are missing or broken.
- (5) Door clearances at the door edge to the frame, on the pull side of the door, do not exceed clearances listed in 4.8.4 and 6.3.1.
- (6) The self-closing device is operational, that is, the active door completely closes when operated from the full open position.
- (7) If a coordinator is installed, the inactive leaf closes before active leaf.
- (8) Latching hardware operates and secures the door when it is in the closed position.
- (9) Auxiliary hardware items that interfere or prohibit operation are not installed on the door or frame.
- (10) No field modifications to the door assembly have been performed that void the label.
- (11) Gasketing and edge seals, where required, are inspected to verify their presence and integrity.

### Swinging Fire Door Components (6.1.2)

- components of a fire door assembly include a door, a door frame, hinges, a lock or latch, and a closing device
- components may also include an astragal, an automatic louver, a coordinator, flush or surface bolts, casketing, a holder/release device, protection plates, and glazing units

### Operation of Doors (6.1.4)

- All swinging fire rated doors shall be closed and latched at the time of fire

### Clearances (6.3.1.7)

- Clearances between the door and the frame shall be 1/8" +/- 1/16" for steel doors
- Clearances between the door and the frame shall not exceed 1/8" for wood doors
- Clearances at the meeting edges of pairs of doors shall be 1/8" +/- 1/16" for steel doors
- Clearances at the meeting edges of pairs of doors shall not exceed 1/8" for wood doors

### Multiple Opening Door Frames (6.3.5)

- Individual frame sizes per the manufacturer's listing, not to exceed 12'8" in overall width
- Multiple opening frames adjoin each other in a fire-resistive wall, they must be separated by a minimum 16" wall section

### Assembly Components (6.4)

#### Closing Devices (6.4.1)

- A closing device shall be required on every fire door.
- All closing devices shall be adjusted to insure positive latching on each door operation.

#### Coordinating Device (6.4.1.2)

- Coordinators are required if a latch bolt or astragal can prevent the inactive door from closing and latching.

#### Hinges (6.4.3.1)

- hinges shall be made of steel, labeled continuous hinges are permitted in accordance with their listing
- Mortise hinges shall be attached to doors with steel screws, surface hinges shall be attached with steel through-bolts (if shims are used, they must be fabricated from steel).
- Doors up to 60 inches in height shall have 2 hinges, and an additional hinge for each additional 30 inches of height or fraction thereof. Distance between hinges may exceed 30".
- Non-spring hinges shall be ball-bearing type, spring hinges shall be labeled, pivots may be used if approved and listed.

#### Shimming (6.4.3.4)

- Shimming of hinges to attain permitted clearances requires the use of steel shims

### Locks or Latches (6.4.4)

- Any lock, latch, or fire exit hardware shall meet both life safety and fire protection requirements.
- Fire exit hardware to be installed only on doors labeled "Fire Door to be Equipped with Fire Exit Hardware".
- All single doors and active leaves of pairs shall have an active latch bolt that cannot be held retracted –
  - Except doors not in a means of egress may have dead bolts in addition to the active latch bolts or as permitted by the AHJ.

### Locks or Latches (6.4.4) Continued

- Locks with interconnected dead bolts which are retracted when the latch bolt is retracted are permitted.
- Automatic fail-safe devices which are activated by the fire protection system and become positively latched upon activation are permitted.
- Latch throw shall be as specified in the manufacturer's installation instructions.
- The inactive leaf on all pairs of doors, where not required for exit purposes shall have labeled self latching, or automatic flush bolts. Manual bolts can be used on rooms not normally occupied by humans (e.g. transformer vaults and storage rooms) (6.4.4.5.1)
- Doors in the means of egress shall not have dead bolts, unless the deadbolt is retracted when the latch bolt is retracted.

### Protection Plates (6.4.5)

- Protective Plates more than 16" high require specific door manufacturer's listing.
- Factory installed protection plates permitted per the door manufacturer's listing.
- Field installed protection plates shall be labeled and installed per their listing

### Astragals (6.4.7)

- There is no specific requirement for an astragal on doors rated more than 1-1/2 hours. Check individual manufacturer's listing for astragal requirements.
- If an astragal is required, it must comply with the manufacturer's listing
- Doors in the means of egress, equipped with astragals, shall not inhibit the free use of either leaf.

### Gasketing (6.4.8)

- Any gasketing used on fire doors shall be fire rated for its intended use.

### Installation (6.5)

- All devices shall be installed in accordance with the manufacturers' instructions and shall be adjusted to function as described in the listing.

### Temperature Rise (Annex D.7)

- Where fire doors are used in stairway enclosures, such doors shall be constructed so that the maximum transmitted temperature end point shall not exceed 450 degrees (F) above ambient temperature at the end of 30 minutes of the standard fire exposure test.

### New in 2007. . .

#### Care and Maintenance

- A field modification of a fire rated door assembly does require that the laboratory whose label is on the assembly be contacted for authorization (5.1.5.2).
- Fire door assemblies shall be inspected and tested annually. A written record shall be kept.
- Functional testing shall be performed by knowledgeable individuals.

# Highlights of NFPA 80 - Standard for Fire Doors and Fire Windows 1999

Note: Numbers in brackets ( ) refer to applicable sections of the publication

## **New Developments** (1-2)

- new products - manufacturer is responsible for furnishing information
- AHJ is responsible for approving devices not described in NFPA 80

## **Job-Site Hardware Preparation** (1-3.4)

- job-site prep for surface-applied hardware, function holes for mortise locks, viewers, 3/4" max. undercutting and protection plates acceptable
- round holes through face of door only
- 1" diameter maximum except cylinder holes

## **Glazing Material** (1-7)

- labeled fire resistance-rated glazing material in labeled lite kits
- allowable size of lite depends on type of glass and fire-testing
- rule of thumb:
  - 1/2 & 1/3 hour rated - limited to maximum area tested (rule of thumb is 1296 square inches per lite)
  - 3/4 hour rated - 1296 square inches per lite, no dimension larger than 54", unless otherwise tested
  - 1 hour, 1 1/2 hour - limited to maximum area tested (100 square inches max. in temperature rise doors)
  - 3 hour rated - 100 square inches

## **Lintels** (1-11.3) (previously 2-2)

- Lintels shall be brick, steel, reinforced concrete, or concrete/masonry arches
- The AHJ can allow other types of lintels

## **Sills** (1-11.2) (previously 2-3)

- sills shall be constructed of noncombustible materials
- frames with a 4" jamb depth or less - sill width shall be equal to the jamb depth
- frames with a jamb depth greater than 4" - sill width shall be 4" minimum and shall be installed so that the sill extends from the face of the frame on the door side into the frame
- combustible floor covering shall not extend through 3-hour rated openings

## **Swinging Doors with**

### **Builders Hardware Assembly Components** (2-4)

- normal components of a fire door assembly include a door, a door frame, hinges, a lock or latch, and a closing device
- components may also include an astragal, an automatic louver, a coordinator, flush or surface bolts, gasketing, a holder/release device, protection plates, and glazing units

### **Door Frames & Clearances** (1-11.4 & 2-3.1.7) (previously 2-5)

- door frames for drywall installation shall be the wrap-around type
- door frames with expansion bolt anchors are for use in masonry walls only
- clearances
  - head, jams, and meeting stiles on pull side - 1/8" +/- 1/16" for metal doors, 1/8" maximum for wood doors (steel hinge shims may be used to meet these clearances - 2-4.3.4)
  - bottom of door - 3/8" max. between bottom of door and raised noncombustible sill, 3/4" max. between bottom of door and floor where there is no sill, 5/8" max. between bottom of door and rigid floor tile, 1/2" max. between bottom of door and nominal surface of floor coverings

### **New in 1999 . . .**

"15-2.5.4 When holes are left in a door or frame due to changes or removal of hardware or plant-ons, the holes shall be repaired by the following methods:

- (a) Install steel fasteners that adequately fill the holes
- (b) Fill the screw or bolt holes with the same material as the door or frame"

**Hinges (2-4.3.1) (previously 2-8.1)**

- hinges shall be made of steel, Labeled continuous hinges are permitted in accordance with their listing
- mortise hinges shall be attached to doors with steel screws, surface hinges shall be attached with steel through-bolts (if shims are used, they must be fabricated from steel)
- doors up to 60 inches in height shall have 2 hinges, and an additional hinge for each additional 30 inches of height or fraction thereof
- non-spring hinges shall be ball-bearing type, spring hinges shall be labeled, pivots may be used if approved and listed

**Locks or Latches (2-4.4) (previously 2-8.2)**

- fire doors with exit devices must have fire exit hardware
- all single doors and active leaves of pairs shall have an active latch bolt that cannot be held retracted
  - except doors not in a means of egress may have dead bolts in addition to the active latch bolts or as permitted by the AHJ
  - locks with interconnected dead bolts which are retracted when the latch bolt is retracted are permitted
  - automatic fail-safe devices which are activated by the fire protection system and become positively latched upon activation are permitted

**Protection Plates (2-4.5) (previously 2-8.3)**

- factory-installed protection plates shall be installed in accordance with the listing of the door
- field-installed protection plates shall be labeled and installed in accordance with their listing
  - exception: labeling is not required where the top of the plate is not more than 16" above the bottom of the door

**Closing Devices (2-4.1) (previously 2-8.5)**

- where there is an astragal or latch bolt that prevents the inactive door from closing and latching before the active door closes and latches, a coordinating device shall be used
- a coordinating device shall not be required where each door closes and latches independently
- where pairs of doors are provided for mechanical equipment rooms to allow the movement of equipment, the closing device may be omitted on the inactive leaf if approved by the AHJ
- closing devices shall be attached to doors and frames by steel screws or through-bolts
- all swinging doors shall be closed and latched at the time of fire

**Astragals (2-4.7) (previously 2-9)**

- pairs of doors rated for more than 1 1/2 hours shall have an overlapping astragal unless otherwise tested and approved
- pairs of doors in a means of egress shall not be equipped with astragals that inhibit the free use of either leaf

**Gasketing (2-4.8) (previously 2-10) -**

- Any gasketing used on fire doors shall be fire rated for its intended use.

**Temperature Rise (E-7)**

- where fire doors are used in stairway enclosures, such doors shall be constructed so that the maximum transmitted temperature end point should not exceed 450 degrees (F) above ambient temperature at the end of 30 minutes of the standard fire exposure test

**Did you Know?**

The 2002 Edition of NFPA 70 National Electric Code requires certain electric rooms to have doors that open in the direction of egress and are "equipped with panic bars, pressure plates, or other devices that are normally latched but open under simple pressure." According to Article 110 of the 2002 NFPA 70 National Electric Code, personnel doors serving the following types of rooms must comply:

- Rooms housing large equipment - 600 Volts, nominal or less, 1200 amperes or more.
- Rooms housing conductors and equipment used on circuits of over 600 Volts, nominal.
- Transformer Vaults

# Highlights of the ADA - Americans with Disabilities Act

July 23, 2004 Edition

Note: Numbers in brackets ( ) refer to applicable sections of the publication.

## Clear Opening Width (404.2.3)

- 32" (815mm) minimum clear opening width required for swinging doors
  - measured with door open 90°, face of door to stop on strike jamb
- openings more than 24" (610 mm) deep - 36" (915 mm) clear opening required
- at least one leaf of a pair must comply (the active leaf)
- "There shall be no projections into the required clear opening width lower than 34"(865mm) above the floor or ground. Projections into the clear opening width between 34 inches (865mm) and 80 inches (2030mm) above the floor or ground shall not exceed 4" (100 mm).  
*Exception:* 1. In alterations a projection of 5/8"(16 mm) maximum into the required clear opening width shall be permitted for the latch side stop." 2. Door closers and door stops shall be permitted to be 78 inches (1980 mm) minimum above the finish floor or ground.

## Thresholds (404.2.5)

- 1/2" (13mm) high maximum
- change in level of 1/4" (6.4 mm) may be vertical; change in level of 1/4" (6.4 mm) to 1/2" (13 mm) must be beveled with a slope not steeper than 1:2; change in level over 1/2" (6.4 mm) must be a ramp sloped 1:12
- *Exception:* Existing or altered thresholds 3/4" (19 mm) high maximum that have a beveled edge on each side with a slope not steeper than 1:2 shall not be required to comply with 404.2.5

## Door Hardware (404.2.7)

- controls and operating mechanisms shall be operable with one hand and shall not require tight grasping, tight pinching, or twisting of the wrist
- force required to activate controls and operating mechanisms - 5 lb (22.2 N) max.
- mounted 34" (22.2 N) to 48" (1220 mm) above the floor or ground (except locks used for security purposes only)
- operating hardware for sliding doors must be exposed and usable from both sides when doors are fully open

## Closing Speed (404.2.8)

- current requirement: 3 seconds minimum from open position of 70° to a point 3" (75 mm) from the latch, proposed:
- door closers - 5 seconds minimum from open position of 90° to 12° (delayed action is not a code requirement)
- spring hinges - 1.5 seconds minimum from open position of 70° to closed position, measured under ambient conditions

## Opening Force (404.2.9)

- interior hinged doors: 5 lbf. (22.2N) maximum; sliding or folding doors: 5 lbf. (22.2N) maximum, exterior hinged doors: not mentioned
- fire doors: minimum allowed by the appropriate administrative authority (size 3 closer recommended for 3' wide interior fire doors per NFPA 80)
- Advisory 404.2.9 Door and Gate Opening Force. The maximum force pertains to the continuous application of force necessary to fully open a door, not the initial force required to overcome the inertia of the door. It does not apply to the force required to retract bolts or to disengage other devices used to keep the door in a closed position.

## Door Surface (404.2.10)

- bottom 10" (255 mm) of swinging doors shall have a smooth surface on the push side extending full width of door
- parts creating horizontal or vertical joints shall be within 1/16" (1.6 mm) of the same plane as the other
- cavities created by added kick plates shall be capped
- *exceptions:* sliding doors, tempered glass doors without stiles with a tapered bottom rail, doors that do not extend to within 10" (255 mm) of the ground

## Vision Lites (404.2.11)

- Vision lites in doors and sidelites adjacent to doors - bottom of at least one lite must be 43"(1090mm) maximum above the floor or ground

## Automatic Doors (404.3)

- must comply with ANSI/BHMA A156.10 (2005 Edition high energy) or A156.19 (2007 Edition low energy)
- clear opening width - 32" (815 mm) minimum - based on clear opening provided by all leafs in the open position
- mount actuators between 36" (915 mm) and 48" (1219 mm) above the floor or ground

On January 14th, 2004, the Access Board unanimously approved new guidelines covering access to facilities covered by the Americans with Disabilities Act (ADA). The approved rule overhauls the existing ADA Accessibility Guidelines (ADAAG), which were first published in 1991. The rule also revises guidelines for federally funded facilities required to be accessible under the Architectural Barriers Act (ABA).

# Highlights of ICC/ANSI A117.1 Accessible and Usable Buildings and Facilities 2003

Note: Numbers in brackets ( ) refer to applicable sections of the publication

## Clear Opening Width (404.2.2)

- 32"(815 mm) minimum clear opening width required for swinging doors (see figure 1)
  - measured with door open 90°, face of door to stop on strike jamb
  - openings more than 24" (610 mm) deep - 36" (915 mm) clear opening required
  - at least one leaf of a pair must comply (the active leaf)

## Thresholds (404.2.4 & 303)

- 1/2" (13 mm) high maximum
- changes in level: (see figure 2)
  - 1/4" (6.4 mm) high maximum vertical change
  - 1/4"(6.4 mm) to 1/2" (13 mm) high - beveled with a slope of 1:2 maximum
  - over 1/2" - ramp is required (maximum slope = 1:12)
- *Exception:* 404.2.4 shall not apply to existing or altered thresholds 3/4" (19mm) maximum in height that have a beveled edge on each side with a maximum slope of 1:2 for the height exceeding 1/4" (6.4 mm)

## Door Hardware (404.2.6)

- shape of operating devices must be easy to grasp with one hand (see figure 3)
- no tight grasping, tight pinching, or twisting of the wrist to operate
- located 34" (865 mm) minimum to 48" (1220 mm) maximum above finished floor
- *Exception:* Locks used only for security purposes and not used for normal operation are permitted in any location.

## Closing Speed (404.2.7)

- door closers - 5 seconds min. from open position of 90° to 12° (delayed action is not a code requirement)
- spring hinges - 1.5 seconds min. from open position of 70° to closed position, measured under ambient conditions

## Opening Force (404.2.8)

- exterior hinged doors: not mentioned
- interior hinged doors: 5 (22.2 N) pounds maximum, except for fire doors
- sliding or folding doors: 5 (22.2 N) pounds maximum
- fire doors:
  - minimum allowed by the appropriate administrative authority
  - (size 3 closer recommended for 36" wide interior fire doors per NFPA 80)

## Door Surface (404.2.9)

- bottom 10" (255 mm) of swinging doors shall have a smooth surface on push side extending full width of door
- parts creating horizontal or vertical joints shall be within 1/16" (1.6 mm) the same plane as the other
- cavities created by added kick plates shall be capped
- *Exception:* sliding doors, tempered glass doors without stiles with a tapered bottom rail, doors that do not extend to within 10" of the ground

## Vision Lites (404.2.11)

- vision lites in doors and sidelites adjacent to doors - bottom of at least one lite must be 43 inches maximum above the floor or ground

## Automatic Doors (404.3)

- comply with ANSI/BHMA A156.10 (high energy) or A156.19 (low energy)
- clear opening width - 32" (815 mm) inches minimum - based on clear opening provided by all leaves in the open position
- mount actuators between 36" (915 mm) and 48" (1220 mm) above the floor or ground

### The 2003 edition of ICC/ANSI A117.1 reads:

"...There shall be no projections into the clear opening width lower than 34 inches (865 mm) above the floor or ground. Projections into the minimum clear opening width more than 34 inches (865 mm) and up to 80 inches (2020 mm) above the floor or ground are permitted but shall not exceed 4 inches (102 mm)."

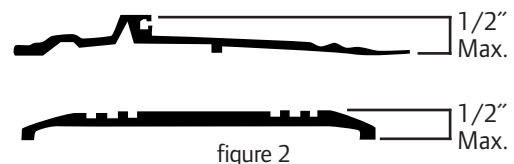
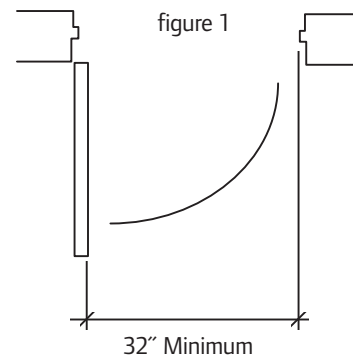

figure 3

# De-Coding Panic Hardware

Panic hardware, also known as an exit device (or fire exit hardware when used on fire doors), is designed to provide fast and easy egress to allow building occupants to exit safely in an emergency. The majority of the codes researched for this article define panic hardware as, "a door-latching assembly incorporating a device that releases the latch upon the application of a force in the direction of egress travel." Panic hardware can be classified as either the touch-pad or push-pad type device, or the cross-bar device.

## Where panic hardware is required by code:

*The International Building Code (2004 Supplement, 2006):*

Each door in a means of egress equipped with latches or locks serving:

- Assembly or Educational Occupancies with an occupant load of 50 people or more.
- High Hazard occupancies (any occupant load).

*The International Building Code (2003):*

Each door in a means of egress equipped with latches or locks serving:

- Assembly or Educational Occupancies with an occupant load of 100 people or more.
- High Hazard (H-1, H-2, H-3, or H-5) Occupancies (any occupant load).

NFPA 101® (2003, 2006), NFPA 5000® (2003, 2006)

Required means of egress doors equipped with latches or locks serving:

- Assembly, Educational, or Day Care Occupancies with an occupant load of 100 people or more.
- High hazard contents areas with an occupant load in excess of 5.

BOCA National Building Code (1999):

Doors equipped with latching devices serving:

- Use Groups A (Assembly) and E (Educational) with an occupant load greater than 100 people.

The Uniform Building Code™ (1997):

Exit and exit-access doors equipped with latches or locks serving:

- Assembly and Institutional Occupancies with an occupant load of 50 people or more.
- Rooms in Educational Occupancies with an occupant load of 50 people or more, and corridor doors in Educational Occupancies.
- UBC - Exit and exit-access doors from rooms in Group H, Divisions 1, 2, 3, 6, and 7.

Panic hardware is only required by code if both criteria are met; the occupancy type must be one of those listed above, and the occupant load must be more than 50 people, or 100 people depending on the code referenced. Although NFPA 101® and NFPA 5000™ are the only codes discussed in this article which have a separate classification for Day-Care Occupancies, all of the other referenced codes consider day-care facilities of a certain size as Educational Occupancies. Therefore, the requirement for panic hardware would apply if the day-care facility had the appropriate occupant load. In some cases, panic hardware may not be required on the main exit door serving an Assembly Occupancy or on stadium gates. Consult the applicable code for these exceptions.

NFPA 70 - The National Electric Code (2002, 2005) requires that certain electric rooms have doors that open in the direction of egress and are "equipped with panic bars, pressure plates, or other devices that are normally latched but open under simple pressure."

Technically, a hospital latch or paddle-type release would meet this requirement, but the fact that the words "panic bar" are used in the Code has prompted many code officials to require panic hardware. According to Article 110 of NFPA 70, personnel doors serving the following types of rooms must comply:

- Rooms housing large equipment - 600 Volts, nominal or less, 1200 amperes or more.
- Rooms housing conductors and equipment used on circuits of over 600 Volts, nominal.
- Transformer Vaults

The IBC also refers to panic hardware for electric rooms:

"Electrical rooms with equipment rated 1,200 amperes or more and over 6 feet (1829 mm) wide that contain overcurrent devices, switching devices or control devices with exit access doors shall be equipped with panic hardware and doors shall swing in the direction of egress."

The AHJ may request panic hardware in other instances if he or she believes that panic hardware is required for life safety. Of course, panic hardware may also be used in locations where it is not required by Code, for ease of use or ability to withstand abuse. If a door is not equipped with a latch or lock (push/pull application), the door is not required to have panic hardware. Keep in mind that when an application requires panic hardware, all of the doors in the means of egress from that room or area will typically require panic hardware, including the exit access, the exit, and the exit discharge. The exception to this rule is the code requirement for panic hardware on electric rooms, which includes only the personnel door leading from the electric room.

### Mounting heights for panic hardware vary by Code:

- NFPA 101® - Between 34" and 48" above the floor.  
Existing installations may be 30 inches above the floor.
- NFPA 5000™ - Between 34" and 48" above the floor.
- IBC - Between 34" and 48" above the floor.
- BOCA, SBC, UBC - Between 30" and 44" above the floor.

### The effect of panic hardware on clear opening width:

For egress and accessibility purposes, the clear width of a door opening is generally required to be a minimum of 32 inches. For pairs of doors, at least one door leaf must comply with the 32-inch requirement. In some cases, such as existing doors and doors to dwelling units, the clear width may be reduced, and occasionally the minimum clear width is increased, as in health care occupancies.

There has been some confusion surrounding the method of measuring the clear width of door openings, specifically whether or not the projection of hardware should be taken into account. Many code officials originally interpreted the requirement to mean that they should open the door to 90 degrees, and then measure from the stop on the strike jamb of the frame to the face of the door, or to the exit device, if one was used. This method of measurement created a problem when using exit devices on 36-inch wide doors with standard hinges.

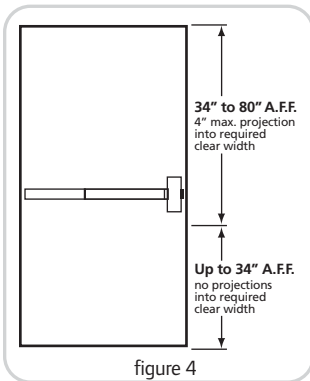

Fortunately, several codes and standards now include language that details how the clear width of door openings is to be measured. The following language appears in the 2003 edition of the International Building Code®: (see figure 4) "1008.1.1.1 Projections into clear width. There shall not be projections into the required clear width lower than 34 inches (864 mm) above the floor or ground. Projections into the clear opening

width between 34 inches (864 mm) and 80 inches (2032 mm) above the floor or ground shall not exceed 4 inches (102 mm)."

Many of the other referenced publications contain similar text. NFPA 101® and NFPA 5000™ add an additional constraint, allowing projections on the hinge side of the door opening only (no projections on the strike side). In the 2003 editions, a new paragraph has been added:

"7.2.1.2.3.2 (NFPA 101®) or 11.2.1.2.3.2 (NFPA 5000™) For swinging doors, projections of not more than 4 in. (100 mm) into the doorway width on the hinge side shall not be considered reductions in width, provided such projections are for purposes of accommodating panic hardware or fire exit hardware and are located not less than 34 in. (865 mm) above the floor."

As long as the panic hardware is mounted at least 34 inches above

the floor and does not project more than 4 inches into the required clear opening width, panic hardware does not affect the measurement of the clear width of door openings.

### Other Requirements:

Where panic hardware is required by Code, the actuating portion of the device (touch-pad or cross-bar) must be at least half the width of the door leaf. A force of 15 pounds applied to the touch-pad or cross-bar must release the latch. No additional locking device (deadlock, chain, padlock & hasp, etc.) may be installed on a door required to have a panic device, and panic hardware may not be equipped with any device that prevents the release of the latch when the touch-pad or cross-bar is pressed. The exception to this is a delayed egress device.

### Fire Doors:

When panic hardware is used on fire doors, it must be fire exit hardware and the door must be equipped with a label stating "Fire Door to be Equipped with Fire Exit Hardware." Fire exit hardware is labeled for panic and fire, and is not equipped with a mechanical "dogging" mechanism. An electric latch retraction device may be used to provide dogging for fire exit hardware, as long as the latch projects automatically upon actuation of the smoke detection system.

### Balanced Doors:

If panic hardware is used on balanced doors (doors where the pivot point is located several inches in from the hinge edge of the door) a push-pad/touch-pad device must be used and the actuating portion of the device must not extend more than half the width of the door. Cross-bar style devices may not be used on balanced doors. The reason for this is that if the actuating portion extended all the way over to the hinge edge of the door, a building occupant could push on the wrong end of the panic device and the door would not open.

The requirements for panic hardware vary significantly by Code. However, as more jurisdictions adopt the International Building Code® or NFPA 5000™ Building Construction and Safety Code™, it should become less complicated to decide when and where to specify and supply panic hardware. The following codes were researched for this article. For more information, determine the code that is being enforced and refer to the appropriate edition of that code.

- International Building Code® (IBC) – 2003, 2004 Supplement, 2006
- BOCA National Building Code (BOCA) - 1999
- NFPA 101® Life Safety Code® (NFPA 101®) – 2003, 2006
- Standard Building Code (SBC) - 1999
- NFPA 5000™ Building Construction & Safety Code (NFPA 5000™) – 2003, 2006
- Uniform Building Code™ (UBC) – 1997

# De-Coding Door Closers

Many codes and standards contain requirements for door closers. Accessibility, fire, and life-safety requirements all have an effect on door closers, but if the product is selected and installed properly, those requirements may not be difficult to meet.

## Accessibility

In the 1980's when the hardware industry began to focus more on standards for accessibility, many people assumed that door closers on an accessible route were required to have the delayed action feature. This feature holds the door open for up to a minute or two, and although it may be convenient for certain locations, it is not a code requirement. In fact, many closers can meet the accessibility guidelines simply by proper adjustment.

## Closing Speed: (see figure 5)

- ICC/ANSI A117.1 Accessible and Usable Buildings and Facilities, 2003 Edition: "404.2.7.1 Door Closers. Door closers shall be adjusted so that from an open position of 90 degrees, the time required to move the door to a position of 12 degrees from the latch is 5 seconds minimum."
- ADA Guidelines, 1994 Edition: "4.13.10\* Door Closers. If a door has a closer, then the sweep period of the closer shall be adjusted so that from an open position of 70 degrees, the door will take at least 3 seconds to move to a point 3 in (75 mm) from the latch, measured to the leading edge of the door." \* (Appendix) "A4.13.10 Door Closers. Closers with delayed action features give a person more time to maneuver through doorways. They are particularly useful on frequently used interior doors such as entrances to toilet rooms." (see figure 6)
- Proposed ADA Guidelines, Approved 2004: "404.2.8.1 Door Closers. Door closers shall be adjusted so that from an open position of 90 degrees, the time required to move the door to a position of 12 degrees from the latch is 5 seconds minimum."

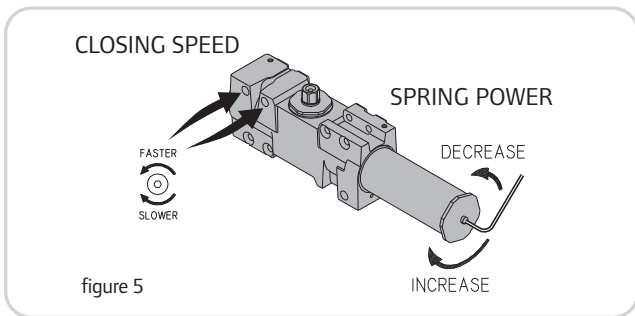

figure 5

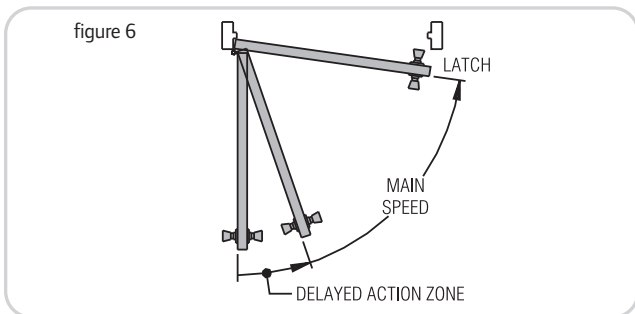

figure 6

## Opening Force:

- ICC/ANSI A117.1 Accessible and Usable Buildings and Facilities, 2003 Edition: "404.2.8 Door Opening Force. Fire doors shall have a minimum opening force allowable by the appropriate administrative authority. The required force for pushing or pulling open a door other than fire doors shall be as follows:
  1. Interior hinged doors: 5 lb (22.2 N) maximum, 2. Sliding or folding doors 5 lb (22.2 N) maximum. These forces do not apply to the force required to retract latch bolts or disengage other devices that hold the door in a closed position." (exterior doors not mentioned)

- ADA Guidelines, 1994 Edition: "4.13.11\* Door Opening Force. The maximum force for pushing or pulling open a door shall be as follows: (1) Fire doors shall have the minimum opening force allowable by the appropriate administrative authority. (2) Other doors. (a) exterior hinged doors: (Reserved). (b) interior hinged doors: 5 lbf (22.2N) (c) sliding or folding doors: 5 lbf (22.2N). These forces do not apply to the force required to retract latch bolts or disengage other devices that may hold the door in a closed position." (Appendix) "A4.13.11 Door Opening Force. Although most people with disabilities can exert at least 5 lbf (22.2N), both pushing and pulling from a stationary position, a few people with severe disabilities cannot exert 3 lbf (13.13N). Although some people cannot manage the allowable forces in this guideline and many others have difficulty, door closers must have certain minimum closing forces to close doors satisfactorily. Forces for pushing or pulling doors open are measured with a push-pull scale under the following conditions:

1. Hinged doors: Force applied perpendicular to the door at the door opener or 30 in (760 mm) from the hinged side, whichever is farther from the hinge.
2. Sliding or folding doors: Force applied parallel to the door at the door pull or latch.
3. Application of force: Apply force gradually so that the applied force does not exceed the resistance of the door. In high-rise buildings, air-pressure differentials may require a modification of this specification in order to meet the functional intent."

- ADA Guidelines, Approved 2004: "404.2.9 Door Opening Force. Fire doors shall have a minimum opening force allowable by the appropriate administrative authority. The required force for pushing or pulling open a door other than fire doors shall be as follows:
  1. Interior hinged doors: 5 lb (22.2 N) maximum, 2. Sliding or folding doors 5 lb (22.2 N) maximum. These forces do not apply to the force required to retract latch bolts or disengage other devices that hold the door in a closed position."

## Fire Doors

One of the cardinal rules of fire-rated doors is that they must be self-closing, but there are many ways to hold open a fire door (see figure 7). A wall- or floor-mounted magnetic holder and a separate mechanical closer may be used if the holder releases upon fire alarm. A closer with an integral electronic holder may either release upon fire alarm or may contain an integral smoke detector. For retrofit applications, a battery-operated holder with an integral smoke detector may be used in conjunction with a separate mechanical closer. According to NFPA 80, Standard for Fire Doors and Fire Windows, 2007 Edition:

- 6.4.1 Closing Devices
  - 6.4.1.1 \* “Unless otherwise permitted by the AHJ, a closing device shall be installed on every fire door.” (Refer to Annex A for exceptions such as the inactive leaf of pairs of doors leading to unoccupied rooms as well as communicating doors between hotel rooms.)
  - 6.4.1.3. “All components of closing devices used shall be attached securely to doors and frames by steel screws or through-bolts.”
  - 6.4.1.4. All closing mechanisms shall be adjusted to overcome the resistance of the latch mechanism so that positive latching is achieved on each door operation.
  - 6.4.1.5. “Where door holder/release devices are used, they shall be labeled.”
- 6-1.4. Operation of Doors. All swinging doors shall be closed and latched at the time of fire.
  - 6.1.4.1 For the purposes of 6.1.4, the operation of doors is divided into three categories:
    1. Self-closing doors
    2. Automatic-closing doors
    3. Power-operated fire doors
  - 6.1.4.2. Self-Closing Doors.
    - 6.1.4.2.1 Self-closing doors shall swing easily and freely and shall be equipped with a closing device to cause the door to close and latch each time it is opened.
    - 6.1.4.2.2 The closing mechanism shall not have a hold-open feature.
  - 6.1.4.3. Automatic Closing Doors. Automatic closing doors shall be permitted to close automatically by means of the installation of a closing device and one of the following:
    1. A separate, labeled, fail-safe door holder/release device or a hold-open mechanism that shall be permitted to be an integral part of the basic closing device
    2. An integral closing device that allows the door to swing freely and that automatically closes the door during an alarm condition provided the hold-open mechanisms are released by one or a combination of automatic fire detectors acceptable to the AHJ.

- “6.1.4.4. Power Operated Fire Doors. Power operated fire doors shall be equipped with a releasing device that shall automatically disconnect the power operator at the time of fire, allowing a self-closing or automatic device to close the door regardless of power failure or manual operation.”

## Life-Safety

The 2006 Edition of NFPA 101® The Life Safety Code®, contains similar requirements:

- 7.2.1.8. Self-Closing Devices.
  - 7.2.1.8. 1\*A door normally required to be kept closed shall not be secured in the open position at any time and shall be self-closing or automatic-closing in accordance with 7.2.1.8.2. unless otherwise permitted by 7.2.1.8.3.
  - 7.2.1.8.2 In any building of low or ordinary hazard contents, as defined in 6.2.2.2 and 6.2.2.3, or where approved by the authority having jurisdiction, doors shall be permitted to be automatic-closing, provided that the following criteria are met.
    1. Upon release of the hold-open mechanism, the door becomes self-closing.
    2. The release device is designed so that the door instantly releases manually and, upon release, becomes self-closing, or the door can be readily closed.
    3. The automatic releasing mechanism or medium is activated by the operation of approved smoke detectors installed in accordance with the requirements for smoke detectors for door release service in NFPA 72, National Fire Alarm Code.
    4. Upon loss of power to the hold-open device, the hold-open mechanism is released and the door becomes self-closing.
    5. The release by means of smoke detection of one door in a stair enclosure results in closing all doors serving that stair.

Note: Portions of some codes and standards have been reprinted here for your reference. For complete requirements, consult the applicable code publication.

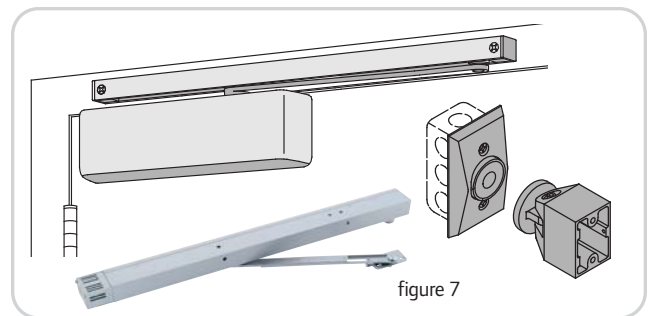

figure 7

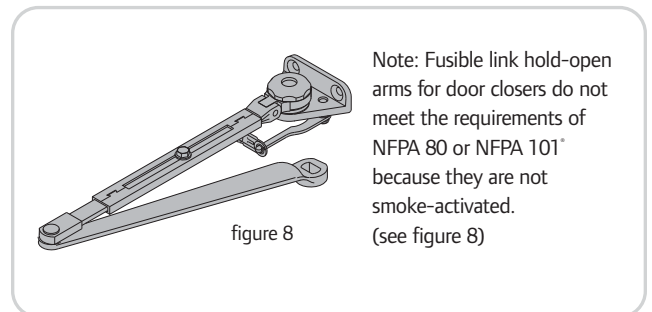

figure 8

Note: Fusible link hold-open arms for door closers do not meet the requirements of NFPA 80 or NFPA 101® because they are not smoke-activated. (see figure 8)

# De-Coding Stairwell Re-Entry

In many buildings, particularly those shared by multiple tenants or departments, there is often a desire to have locks on means of egress stairwell doors, preventing unauthorized entry to a tenant space from the stairwell. However, in a fire emergency, building occupants exiting down a stairwell may find the exit compromised by smoke or flames. In this situation, it's important to allow ingress from the stairwell through a tenant space to another exit. Stairwell re-entry refers to the code requirements surrounding this issue. Keep in mind that these requirements refer to locking the stair doors on the stair side. The egress side of the doors must provide free egress, with very limited exceptions. Also note that in almost all cases the stair discharge door must also provide free egress.

**2006 NFPA 101® Life Safety Code® (7.2.1.5.7)**

**2006 NFPA 5000™ Building Construction and Safety Code™ (11.2.1.5.2)**

Note: These requirements refer to enclosed exit stairs, not to outside stairs.

In stairs serving 4 stories or less, stair doors may be mechanically locked on the stair side.

In stairs serving more than 4 stories, there are 3 options:

1. Re-entry from the stair enclosure to the interior of the building shall be provided (doors are not locked).
2. An automatic release that is actuated with the initiation of the building fire alarm system shall be provided to unlock all stair doors (fail-safe electrified hardware unlocks upon fire alarm).
3. Selected re-entry shall be provided in accordance with the following:
  - a. At least 2 levels must be unlocked.
  - b. There may not be more than 4 locked floors between unlocked floors
  - c. The top or next to the top floor which allows access to another exit must be unlocked.
  - d. There must be signage on the stair side identifying unlocked doors.
  - e. There must be signage on the stair side of locked doors indicating the nearest unlocked door in each direction.

Note: The high-rise chapters of these codes require two-way telephone communication service for fire department use at every level of the stair enclosure, unless the fire department radio system has been approved as equivalent.

The stairwell re-entry requirement does not apply to the following:

1. Existing installations as permitted by the occupancy chapters.
2. Stair enclosures serving a building permitted to have a single exit in accordance with the occupancy chapters.
3. Stair enclosures in health care occupancies where allowed by Chapter 18/19. High-rise health care occupancies must comply with the stairwell re-entry requirements (NFPA 101® - 18.2.2.2.8 / NFPA 5000™ - 19.2.2.2.9). A high-rise building is defined as a building greater than 75 feet in height. The building height is measured from the lowest level of fire department vehicle access to the floor of the highest occupiable story.

4. Stair enclosures in detention and correctional occupancies (NFPA 101® - 22.2.11.9 / NFPA 5000™ - 21.2.11.9).

**2003 International Building Code® (1008.1.8.7 & 403.12)**

The International Building Code® contains essentially the same language as the BOCA National Building Code, except that in stairs serving four stories or less, doors may be mechanically locked on the stair side.

**2006 International Building Code® (1008.1.8.7 & 403.12)**

The 2006 edition of the International Building Code® states that stairs serving four stories or less can be locked on the stair side, but adds the requirement that these doors must be capable of being unlocked simultaneously without unlatching upon a signal from the fire command center, if present, or a signal by emergency personnel from a single location inside the main entrance to the building.

**1999 BOCA National Building Code (1014.11.3 & 403.10)**

The BOCA National Building Code states that stair doors must be openable from both sides without the use of a key or special knowledge or effort. Stair discharge doors must be openable from the egress side and may be locked on the opposite side. Selected re-entry, the locking of some doors in a stairwell, is not mentioned in this code.

The exception to the requirement that all stair doors must be unlocked is means of egress stair doors in high-rise buildings (buildings more than 75 feet above the lowest level of fire department vehicle access). In high-rise buildings, stair doors may be locked on the stair side as long as they are unlocked simultaneously without unlatching by a signal from the fire command center. Note the difference between this requirement that doors be unlocked by a signal from the fire command center and the requirement of NFPA 101®/5000 that the doors are unlocked by an automatic release that is actuated with the initiation of the building fire alarm system. The fire command center is defined as the principal location where the detection, alarm, communications and control system is displayed, and from which the system has the capability for manual control. If doors are electrically locked, a telephone or other two-way communication system connected to an approved constantly attended station must be provided in the stairwell at least every fifth floor.

The Code doesn't specifically mention the use of this type of lock on buildings that are not classified as high-rise buildings, but the BOCA Commentary states that their use would be an acceptable solution for non-high-rise buildings. There is no exception in this code for mechanically locking stair doors in buildings of a specific maximum height. There are very limited exceptions for situations such as penal facilities.

### 1999 Standard Building Code (412.8)

The Standard Building Code contains very similar language to the BOCA National Building Code, but the High-Rise section of the SBC refers only to Group B (Business) and Group R (Residential) high-rise buildings. In addition to being unlocked by a signal from the fire command center, the doors must also unlock upon actuation of the sprinkler system or upon power failure. A telephone or other two-way communication system is required in the stairwell at least every fifth floor, and must be connected to an approved emergency service that operates continuously.

### 1997 Uniform Building Code™ (403.9)

The Uniform Building Code™ allows means of egress stairway doors in certain use groups to be locked as long as they may be unlocked simultaneously without unlatching upon a signal from the central control station. The High-Rise section of the Code refers only to Group B (Business) office buildings and Group R (Residential), Division 1 occupancies (hotels, apartments, congregate residences). A telephone or other two-way communication system is required at least every fifth floor and must be connected to an approved emergency service that operates continuously.

Stairwell Re-Entry Summary Table					
Code	Section	Mechanical Locks	Selected Re-Entry	Electric Locks	Two-Way Communication
NFPA 101	7.2.1.5.7	Allowed on stairs serving 4 stories or less	Yes, Refer to Code	Automatic release actuated by the fire alarm system.	Required at every floor of an exit stair in high-rise buildings, connected to the central control station (except where fire department radio system is an approved equivalent).
NFPA 5000	11.2.1.5.2				
IBC 2006	1008.1.8.7 & 403.12	Not allowed	No	4 stories or less - Unlocked by fire command center or single location at building entrance. High-rise buildings - Unlocked by a signal from the fire command center.	Required every fifth floor in stairs where doors are locked electrically. Device must connect to an approved constantly attended station.
IBC 2003	1008.1.8.7 & 403.12	Allowed on stairs serving 4 stories or less	No	High-rise buildings, Unlocked by a signal from the fire command center (UBC only addresses Use Groups B and R-Div 1).	Required every fifth floor in stairs where doors are locked electrically. Device must connect to an approved constantly attended station or an approved emergency service that operates continuously depending on which Code is used.
BOCA	1014.11.3 & 403.10				
UBC	403.9				
SBC	412.8				
			No	High-rise buildings, (specific to Use Groups B & R), unlocked by a signal from the fire command center, sprinkler system, or power failure.	

### How Do We Accomplish Stairwell Re-Entry?

Several types of hardware may be used for doors that are required to unlock for stairwell re-entry. Fail-safe electrified locks and fail-safe electrified fire exit hardware are two options. If the applicable code allows the use of access-controlled egress doors, an electromagnetic lock may be used. Since most stairwell doors are fire-rated, a stair door equipped with an electromagnetic lock must also have a passage set or passage function fire exit hardware so the door is self-latching. Another option is a stairwell system consisting of a modified mortise lock and an electrified frame-mounted operator/controller. The frame-mounted portion of this system controls the locking and unlocking of the stair side lever. This system must not be confused with an electric strike. A fail-safe electric strike may not be used to accomplish stairwell re-entry because fail-safe electric strikes are not acceptable for use on fire-rated doors. Several codes mention that the locks must unlock but remain latched.

The code requirements for stairwell re-entry vary by code publication so it's extremely important to know which code is being enforced. While NFPA 101®, NFPA 5000™, and the 2003 Edition of the International Building Code® allow some stair doors to be mechanically locked, other codes may not. If you specify or supply

hardware that is in compliance with one code, you may be in violation of another. I have witnessed this first-hand when a local fire marshal asked me to help him find a way to deny the use of mechanical locks on stair doors in a four-story retail store. The fire marshal was enforcing NFPA 101®, which allowed the doors to be mechanically locked. I advised him that the State Building Code did not allow the stair doors to be locked. The fire marshal contacted the building inspector, who enforced the building code, and the locks were removed.

The following codes were researched for this article. For more information, determine the code that is being enforced and refer to the appropriate edition of that code. As always, the code official makes the final decision.

- International Building Code® (IBC) – 2003, 2006
- BOCA National Building Code (BOCA) - 1999
- NFPA 101® Life Safety Code® (NFPA 101®) – 2003, 2006
- Standard Building Code (SBC) - 1999
- NFPA 5000™ Building Construction & Safety Code (NFPA 5000™) – 2003, 2006
- Uniform Building Code™ (UBC) – 1997

# De-Coding Delayed Egress Hardware

Delayed egress hardware prevents a door from being opened from the egress side, usually for a period of 15 seconds. This type of device is often used to prevent theft, while maintaining life safety. The system is most commonly comprised of an exit device incorporating delayed egress features, or an electromagnetic lock and power supply, one of which would contain delayed egress circuitry. When the device is actuated, the door remains locked on the egress side for 15 seconds, and then releases to allow egress.

## Requirements of NFPA 101® The Life Safety Code® and NFPA 5000™ Building Construction and Safety Code™:

The 2006 editions of NFPA 101® (section 7.2.1.6.1) and NFPA 5000™ (section 11.2.1.6.1) state the following requirements for delayed egress locks. All of these requirements must be met.

- The building must be protected throughout by an approved, supervised automatic fire detection system or an approved, supervised automatic sprinkler system, installed in accordance with the applicable section.
- Delayed egress locks must be approved and listed, and must be permitted by the individual occupancy chapters, low and ordinary hazard content areas only (refer to Table 1 for occupancies and conditions for use).
- Devices must release immediately (no delay) upon actuation of the sprinkler system, any heat detector, or not more than two smoke detectors of the fire detection system, and loss of power to the lock.
- Devices must release 15 seconds after a force of 15 pounds is applied for a maximum of 3 seconds (the code official may increase the delay from 15 to 30 seconds). The initiation of the 15-second cycle must be an irreversible process.
- An audible local alarm must sound upon initiation of the release process.
- The system must be rearmed manually.
- Signage must be provided on the door adjacent to the release device stating "PUSH UNTIL ALARM SOUNDS. DOOR CAN BE OPENED IN 15 SECONDS." Letters must be 1" (25 mm) minimum in height, with a stroke width of 1/8" (3.2 mm) minimum, on a contrasting back-ground. If the code official has permitted an increase of the operation time, the sign must state the appropriate time.
- Emergency lighting is required (this requirement is located in section 7.9.1.1 / 11.9.1.1).
- Several occupancies, as well as several of the other referenced codes, require that a building occupant may not encounter more than one delay in a means of egress.

## Notable differences in other codes:

Most of the referenced codes have similar requirements to those of NFPA 101® and 5000, but there are some important differences. One major difference between codes is the occupancy types or use groups where delayed egress hardware may be used (Table 2). For example, while NFPA 101® and 5000™ do not restrict the use of delayed egress hardware on doors in Assembly Occupancies (other than the main entrance/exit), none of the other referenced codes permit the use of delayed egress hardware on any egress

doors in Assembly Occupancies. Libraries, which are a great application for delayed egress hardware, are defined by most codes as Assembly Occupancies, so delayed egress hardware may be prohibited. Also note that neither the IBC nor the UBC allow delayed egress hardware to be used in Educational Occupancies, while NFPA 101®, NFPA 5000™, BOCA, and SBC do allow the use of delayed egress hardware in Educational Occupancies.

Another difference between code requirements is the manner in which the delayed egress system may be initiated and rearmed. Table 3 illustrates these differences. The amount of time that force must be applied before the 15-second cycle begins is important because delayed egress hardware that has been designed to meet NFPA 101® requirements (3-second application of force) may need factory modifications to meet the other codes. Rearming the delayed egress hardware refers to "resetting" the device. Several codes require the device to be manually rearmed by a person going to the door to reset the device. Other codes allow the device to automatically rearm itself after the door has been opened, and in the case of BOCA, only after the door has opened, closed, and remained closed for 30 seconds. For some delayed egress hardware, this would require that a door position switch be added to the system.

Several codes state that the delayed egress device must be able to be released by a signal from a remote location. BOCA requires that the signal originate from an emergency control station, which is "an approved location on the premises where signals from emergency equipment are received and which is staffed by trained personnel." Per the IBC, the signal must originate from the fire command center. The UBC requires the signal switch to be in an "approved location."

**Table 1: Occupancies Permitting Delayed Egress Locks NFPA 101 & NFPA 5000, 2006 Editions**

Occupancy	Condition
Assembly	Only doors other than main entrance/exit doors may be equipped with delayed egress locks.
Educational, Day Care	No restrictions
Health Care Lodging and Rooming Houses Hotels and Dormitories Apartment Buildings	Not more than one delayed egress device may be encountered in any egress path.
Residential Board and Care	Exterior doors only. Not more than one delayed egress device may be encountered in any egress path.
Ambulatory Health Care	No restrictions (Editions of NFPA 101 prior to 2003 limit the use of delayed egress devices in ambulatory health care occupancies to exterior doors.)
Mercantile, Business, Industrial, Storage	No restrictions

**What about battery backup?**

Unfortunately, this article will not give a definitive answer to this common question. In some applications, it may be desirable to use battery backup to ensure that delayed egress hardware will remain armed in the case of power failure. Each of the referenced codes has slightly different statements regarding loss of power, as illustrated by Table 4. The SBC is the only code that specifically states that “independent standby power” is acceptable under certain conditions.

The gray area is in the definition of “loss of power”. I solicited informal opinions from engineers at two of the model code groups, and the engineers agreed that “power” could be defined as the building’s primary power source, back-up generator power, or even battery power. If power is provided by any means, the engineers felt that it is acceptable for the device to be armed with the 15-second delay, as long as all of the other code requirements are met. One of the engineers pointed out that the codes say “loss of power” rather than “loss of primary power”, and felt that the code would have been more specific if the intent was to distinguish between different power conditions. Until the codes (other than the SBC) are more specific about this requirement, the final decision must be made by the local code official.

To understand and follow the code requirements for delayed egress hardware, you must consult the appropriate edition of the code that is being enforced for the project in question. The following codes were researched for this article. For more information, determine the code that is being enforced and refer to the appropriate edition of that code.

- International Building Code® (IBC) – 2003, 2006
- BOCA National Building Code (BOCA) – 1999
- NFPA 101® Life Safety Code® (NFPA 101®) – 2003, 2006
- Standard Building Code (SBC) – 1999
- NFPA 5000™ Building Construction & Safety Code (NFPA 5000™) – 2003, 2006
- Uniform Building Code™ (UBC) – 1997

Code - Edition	Occupancies/Use Groups
NFPA 101/5000 - 2003	Allowed in all occupancies with some conditions for use. Refer to Table 1.
IBC - 2003	Allowed in all occupancies EXCEPT A (Assembly), E (Educational), and (H) High Hazard.
BOCA - 1999	Allowed in Use Groups B (Business), E (Educational), F (Factory and Industrial), I (Institutional), M (Mercantile), S (Storage), and R (Residential).
SBC - 1999	Allowed in all use groups except Group A (Assembly)
UBC - 1997	Allowed (when approved by the building official) in Group B (Business), F (Factory & Industrial), I (Institutional) - Division 2 only (nursing homes for ambulatory patients, homes for children 6 years of age or over, each accommodating > 5 patients or children), M (Mercantile), R (Residential) - Division 1 only (congregate residences serving as group-care facilities only) and Group S (Storage).

Code - Edition	15-Second Cycle Initiated By:	Rearming:
NFPA 101/5000 – 2003, 2006	15 pounds applied for 3 seconds.	Must be manually rearmed.
IBC – 2003, 2006	15 pounds applied for 1 second.	Must be manually rearmed.
BOCA - 1999	15 pounds applied for 1 second.	Device may automatically rearm after door has been opened and returned to the closed position for at least 30 seconds (45 seconds when approved by the code official). Reopening the door shall restart the 30-second rearm cycle.
SBC - 1999	15 pounds, time limit not stated in the Code.	Device may automatically rearm after door has been opened. No time limit stated in the Code.
UBC - 1997	15 pounds applied for 2 seconds.	Must be manually rearmed.

Code - Edition	Code Excerpt:
NFPA 101/5000 – 2003, 2006	“The doors shall unlock upon loss of power controlling the lock or locking mechanism.”
IBC – 2003, 2006	“The doors unlock upon loss of power controlling the lock or lock mechanism.”
BOCA - 1999	Egress control devices shall unlock in accordance with: “Loss of power to the egress control device. Loss of power to the building.”
SBC - 1999	“Independent standby power is acceptable as long as the supervised automatic smoke detection system, automatic fire detection system, or automatic sprinkler system, when activated, has precedence over the standby power and unlocks the door. If a non-emergency situation occurs such as a power outage, the door shall be allowed to remain locked until the detection system(s) operate, provided that the power outage does not disable these detection systems. If any of the detection systems are disabled in any way, standby power controlling the locking devices will be interrupted.”
UBC - 1997	“The egress-control device shall automatically deactivate upon loss of electrical power to any one of the following: The egress-control device itself. The smoke detection system. Means of egress illumination as required by section 1003.2.9.”

# De-Coding Access-Controlled Egress Doors

When an egress door is equipped with an electromagnetic lock, it must comply with the code requirements for Access-Controlled Egress Doors. Electromagnetic locks are basically a magnet mounted on the door frame and a steel armature mounted on the door. When the magnet is energized, it bonds to the armature and locks the door. When power is cut to the magnet, the door is unlocked. Unlike most mechanical locksets which normally allow free egress, an electromagnetic lock will not allow egress unless the required release devices are installed on the egress side.

## Requirements of NFPA 101® The Life Safety Code® and NFPA 5000™ Building Construction and Safety Code™:

The 2003 editions of NFPA 101®, The Life Safety Code® (Section 7.2.1.6.2), and NFPA 5000™ Building Construction and Safety Code™ (Section 11.2.1.6.2) state the following requirements for access-controlled egress doors:

- Access-controlled egress doors must be permitted by the applicable occupancy chapter, and
- One of the following must be provided:
  - a sensor on the egress side which unlocks the door upon detection of an occupant approaching the door, or
  - listed panic or fire exit hardware that, when operated, unlocks the door, and
- The door shall unlock upon loss of power to the locking device, and
- A manual release device (push button) shall be provided to unlock the door, and shall be located 40-48 inches above the floor, and within 5 feet of the door. The manual release device shall be equipped with signage - "Push to Exit", and shall interrupt power to the lock, independent of the access-control system. Door shall remain unlocked for at least 30 seconds, and
- If the building is equipped with a fire protective signaling system, automatic sprinkler system, or fire detection system, actuation of such shall unlock the door, and the door shall remain unlocked until the system is manually reset.

Note: all of the above requirements must be met

The 2003 edition of NFPA 101 was the first to include the language regarding a panic device with an integral switch being used as a release device for an access-controlled egress door. The 2006 edition removed that language, and reverted back to the previous requirement for a sensor to detect an occupant approaching the door which unlocks the door in the direction of egress. At first glance it would appear that a panic device with a switch is not acceptable for releasing this type of lock. However, after a long discussion with NFPA staff and some time spent reading the 2006 Life Safety Code Handbook, it appears that NFPA has clarified this section of the code. A door equipped with an electromagnetic lock and a door-mounted release such as a panic device or lockset with a request-to-exit switch is not considered an access-controlled egress door and is not required to meet this section of the code. Keep in mind that the AHJ may enforce more stringent requirements.

The 2006 edition of NFPA 101 adds two other important clarifications as well. Item (7) in section 7.2.1.6.2 states:

“The activation of manual fire alarm boxes that activate the building fire protective signaling system specified in 7.2.1.6.2(6) shall not be required to unlock the doors.”

The other clarification is found in section 7.9.1.1, which states that new access-controlled egress doors are required to have emergency lighting.

The 2006 Life Safety Code Handbook states, “The special locking arrangements described in 7.2.1.6 include delayed-egress locks and access-controlled egress doors. Each of these terms has a specific, but limited, meaning for purposes of applying the Code. For example, a building operator installs a magnetic lock on an outside door and provides a card reader outside the building that releases the door lock, so that only authorized persons are allowed entry to the building. Further, a lever handle is mounted on the inside surface of the door and has an integral switch that releases the magnetic lock whenever a building occupant operates the lever. The building operator refers to this system as an access-controlled egress door, but it is not the access-controlled egress door addressed in 7.2.1.6.2, and it is not subject to those requirements. Rather, the door-locking system described is a normal door in compliance with 7.2.1.5.1, 7.2.1.5.2, and 7.2.1.5.9. The concept is further explained by the third sentence of A.7.2.1.5.9 and A.7.2.1.6.2, both of which are new to the 2006 edition of the Code.”

Paragraph A.7.2.1.5.9 states:

“...It is also within the intent of this requirement that switches integral to traditional door knobs, lever handles, or bars, and that interrupt the power supply to an electromagnetic lock, be permitted, provided that they are affixed to the door leaf...”

Paragraph A.7.2.1.6.2 states:

“It is not the intent to require doors that restrict access but comply with 7.2.1.5.9 to comply with the access-controlled egress door provisions of 7.2.1.6.2.”

**Table 1: Occupancies Permitting Access-Controlled Egress Doors - NFPA 101 & NFPA 5000, 2003 and 2006 Editions**

Occupancy	Condition
Assembly	Access-controlled egress doors are acceptable, but doors shall not be locked from the egress side when the assembly occupancy is occupied.
Educational, Day Care, Health Care, Ambulatory Health Care, Hotels and Dormitories, Apartment Buildings, Residential Board and Care, Industrial, Storage	No restrictions
Mercantile	Access-controlled egress doors are acceptable in buildings protected throughout by an approved, supervised fire detection or sprinkler system.

Access-controlled egress doors are not mentioned in the following occupancies: Detention & Correctional, Lodging & Rooming Houses.

### Notable differences in other codes:

The other codes researched for this article have very similar requirements to NFPA 101® and NFPA 5000™, but the locations where access-controlled egress doors may be used are more restrictive:

The ICC International Building Code® (section 1008.1.3.4) and the BOCA National Building Code (section 1017.4.5) restrict the location of access-controlled egress doors to entrance doors and tenant entrance doors, in Use Groups A (Assembly), B (Business), E (Educational), M (Mercantile), and R-1 and R-2 (Residential). These codes do not contain specific language allowing the use of a panic device to unlock the lock instead of a sensor. The language in these codes clarifies that “ready access” must be provided to the push button. The use of a glass-break type button would not be acceptable. An additional requirement is included in the IBC and BOCA: “Entrance doors in buildings with an occupancy in Use Group A, B, E, or M shall not be secured from the egress side during periods that the building is open to the general public.”

The ICBO Uniform Building Code™ does not contain any reference to “Access-Controlled Egress Doors” or specific requirements for doors equipped with electromagnetic locks.

The SBCCI Standard Building Code (section 1012.7) restricts the location of access-controlled egress doors to entrance doors and tenant entrance doors in Groups B (Business), M (Mercantile), R1 and R2 (Residential). This code allows alternatives to a motion sensor, such as a panic device with a switch which unlocks the lock: “An approved listed releasing sensor/device, either mechanical or electrical, shall be provided on the egress side arranged to detect an occupant attempting to gain egress. The doors shall be arranged to unlock by a signal from or loss of power to the releasing sensor/device.” A push button is required in addition to the sensor or mechanical release device, and the code states that the button is for “emergency unlock purposes only”. The SBC includes language stating that, “Entrance doors in Group B or M shall not be secured from the egress side during periods that the building is open to the general public.” It also states that “Entrance doors in buildings having a mechanical means of egress in conjunction with an electric strike shall be latched when not energized.”

### What about battery backup?

Similar to the code requirements for delayed egress, most of the codes are unclear about whether battery backup can be used with access-controlled egress doors. Only the SBC has specific language regarding standby power: “Independent standby power, if provided, is acceptable on doors having immediate egress upon activation with a listed releasing sensor/device and, if provided, tie in with the supervised automatic smoke/fire detection or automatic sprinkler system as described in 1012.6.1, Exception 1.” The section referenced in the SBC is the paragraph under Special Locking Arrangements which describes the use of standby power for delayed egress

hardware. The other codes all state that “loss of power” to the lock or sensor must unlock the door. As with delayed egress hardware, the grey area lies in the definition of “power”. If battery back-up is desired and a code other than the SBC is being enforced, the AHJ should be consulted.

To understand and follow the code requirements for access-controlled egress doors, you must consult the appropriate edition of the code that is being enforced for the project in question. The following codes were researched for this article. For more information, determine the code that is being enforced and refer to the appropriate edition of that code.

- International Building Code® (IBC) – 2003, 2006
- BOCA National Building Code (BOCA) - 1999
- NFPA 101® Life Safety Code® (NFPA 101®) – 2003, 2006
- Standard Building Code (SBC) - 1999
- NFPA 5000™ Building Construction & Safety Code (NFPA 5000™) – 2003, 2006
- Uniform Building Code™ (UBC) – 1997

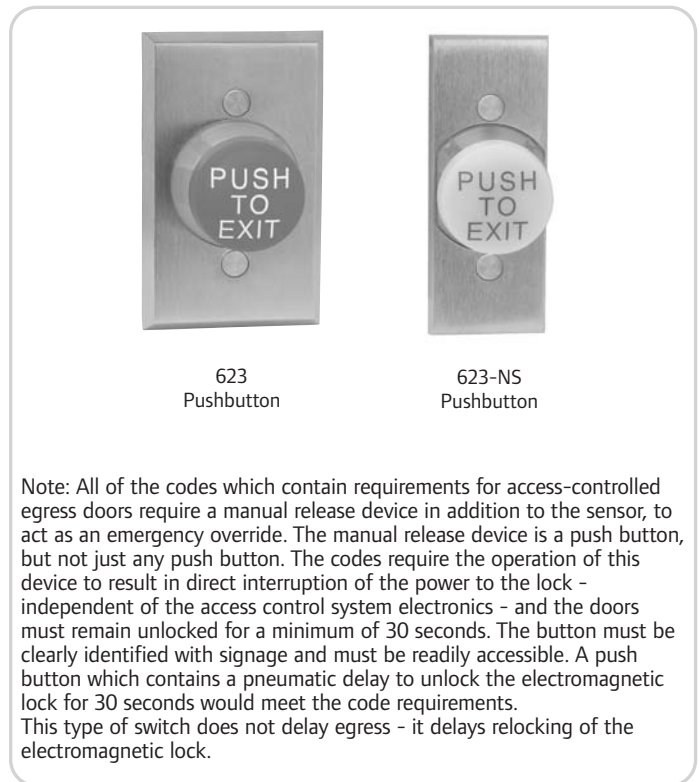

Note: All of the codes which contain requirements for access-controlled egress doors require a manual release device in addition to the sensor, to act as an emergency override. The manual release device is a push button, but not just any push button. The codes require the operation of this device to result in direct interruption of the power to the lock - independent of the access control system electronics - and the doors must remain unlocked for a minimum of 30 seconds. The button must be clearly identified with signage and must be readily accessible. A push button which contains a pneumatic delay to unlock the electromagnetic lock for 30 seconds would meet the code requirements. This type of switch does not delay egress - it delays relocking of the electromagnetic lock.

# Sources for Code Information

## **ADA - Americans With Disabilities Act**

The U.S. Architectural and Transportation Barriers Compliance Board  
1331 F Street, N.W. (Suite 1000), Washington, D.C. 20004-1111, Phone: 800-514-0301  
Website: [www.usdoj.gov/crt/ada/adahom1.htm](http://www.usdoj.gov/crt/ada/adahom1.htm)  
ADA Accessibility Guidelines for Buildings and Facilities (July 1994 - Updated guidelines in progress)

## **ANSI - American National Standards Institute**

25 West 43rd Street, 4th Floor, New York, NY 10036, Phone: 212-642-4900, Fax: 212-398-0023  
Website: [www.ansi.org](http://www.ansi.org)  
ANSI/BHMA A156 - Standards and Directories for Hardware (Various Dates)

## **ICC - International Code Council® Headquarters**

5203 Leesburg Pike, Suite 600, Falls Church, VA 22041, Phone: 703-931-4533, Fax: 703-379-1546  
Website: [www.iccsafe.org](http://www.iccsafe.org)  
ICC/ANSI A117.1 - Accessible and Usable Buildings and Facilities (1998)  
International Building Code® 2006  
2007 Supplement to the International Codes  
The BOCA National Building Code (1999)  
The SBCCI Standard Building Code (1999)  
The ICBO Uniform Building Code™ (1997)

## **ICC - International Code Council® - Birmingham District Office**

900 Montclair Road, Birmingham AL 35213-1206 Phone: 205-591-1853, Fax: 205-591-0775  
Website: [www.iccsafe.org](http://www.iccsafe.org)

## **ICC - International Code Council® - Chicago District Office**

4051 West Flossmoor Rd, Country Club Hills, IL 60478-5795, Phone: 800-214-4321, Fax: 800-214-7167  
Website: [www.iccsafe.org](http://www.iccsafe.org)

## **ICC - International Code Council® - Los Angeles District Office**

5360 Workman Mill Road, Whittier CA 90601-2298, Phone: 800-284-4406, Fax: 888-329-4226  
Website: [www.iccsafe.org](http://www.iccsafe.org)

## **NFPA - National Fire Protection Association**

1 Batterymarch Park, Quincy, MA 02169-7471, Phone: 800-344-3555, Fax: 617-770-0700  
Website: [www.nfpa.org](http://www.nfpa.org)  
NFPA 80 - Standard for Fire Doors and Other Opening Protectives - 2007 Edition  
NFPA 101® - Life Safety Code® (2006)  
NFPA 105 - Standard For The Installation of Smoke Door Assemblies and Other Opening Protectives - 2007 Edition  
NFPA 5000™ - Building Construction & Safety Code (2006)

## **Canadian Codes Centre Institute for Research in Construction**

National Research Council Canada, Building M-23A, 1200 Montreal Road, Ottawa, ON K1A 0R6  
Phone: 613-993-9960, Fax: 613-952-4040  
Website: [www.nationalcodes.ca](http://www.nationalcodes.ca)  
National Building Code of Canada 2005  
National Fire Code of Canada 2005

## **UL - Underwriters Laboratories Inc.**

333 Pfingsten Road, Northbrook, IL 60062, Phone: 847-272-8800, Fax: 847-272-8129  
Website: [www.ul.com](http://www.ul.com)  
UL Building Materials Directory  
<http://database.ul.com/cgi-bin/XYV/template/LISEXT/1FRAME/index.htm>

## **Warnock Hersey / Intertek Testing Services**

3933 US Route 11, Cortlant, New York 13045  
Website: [www.intertek-etlsemko.com](http://www.intertek-etlsemko.com)

## From Consulting To Service, We Respond

Ingersoll Rand stands ready to assist you in any way we can - at any stage of the process. We will consult with you and upgrade or design new systems. Specify and install leading brands in which you can have confidence. Manage and maintain your door openings for the life of your facility. Give you the best warranty in the industry. It starts with our network of security and safety consultants, who can help you find the exact security and safety products to meet your needs.

**For further information, call 1-877-840-3621 or contact your local Ingersoll Rand Security Technologies Consultant at the number listed below.**

## Ingersoll Rand Security Technologies Consultants

### United States

SSC Northern California  
Pleasanton, CA 94566  
sscnortherncalifornia@irco.com  
925-462-4777

SSC Southern California  
Arcadia, CA 91006  
sscsoutherncalifornia@irco.com  
626-359-5555

SSC Carolina  
Davidson, NC 28036  
ssccarolina@irco.com  
704-549-1999

SSC Central  
Olathe, KS 66061  
ssccentral@irco.com  
913-393-8700

SSC Chicago  
Addison, IL 60101  
sscchicago@irco.com  
877-282-1721

SSC Mountain States  
Centennial, CO 80111  
ssccolorado@irco.com  
720-279-5600 - Colorado  
801-349-3686 - Utah

SSC Florida  
Longwood, FL 32750  
sscflorida@irco.com  
407-571-2000

SSC Midwest  
Indianapolis, IN 46250  
sscindiana@irco.com  
317-715-4500

SSC Michigan  
Livonia, MI 48150  
sscmichigan@irco.com  
734-655-8181

SSC Mid-Atlantic  
Wilmington, DE 19809  
sscmidatlantic@irco.com  
302-765-2190

SSC New England  
Needham Heights, MA 02494  
sscnewengland@irco.com  
781-449-2860

SSC Metro New York  
Hawthorne, NY 10532  
sscmetronewyork@irco.com  
914-742-2760

SSC Great Lakes  
Pittsford, NY 14534  
sscupstatenewyork@irco.com  
585-248-1520

SSC North Central  
Eden Prairie, MN 55346  
sscnorthcentral@irco.com  
952-674-4940

SSC Northwest  
Bothell, WA 98011  
sscnorthwest@irco.com  
425-686-3615 - Washington  
360-356-3035 - Oregon

SSC South  
Norcross, GA 30071  
sscsouth@irco.com  
678-906-2103

SSC Southwest  
Tempe, AZ 85281  
sscarizona@irco.com  
480-377-6700

SSC Texas  
Plano, TX 75024  
ssctexas@irco.com  
972-378-1191 - Plano  
713-683-6400 - Houston

### Canada

#### WESTERN CANADA

SSC of British Columbia  
Richmond, BC V7A 4V4  
604-272-5222

SSC of Alberta  
Calgary, AB T2E 7T1  
403-287-1190

SSC of Alberta  
Edmonton, AB T5V 1J7  
780-451-1641

#### PRAIRIES

SSC of Saskatchewan/Manitoba  
Winnipeg, MB R3E 2V2  
204-786-6355

#### ONTARIO

SSC of Ontario  
Mississauga, ON L5E 1E4  
905-403-1800  
877-590-4734

#### QUEBEC & ATLANTIC PROVINCES

SSC of Quebec  
Montreal, PQ H2B 1Z5  
514-385-0005

SSC of Quebec  
St. Nicolas (Quebec City), PQ G7A 5A8  
418-836-5010



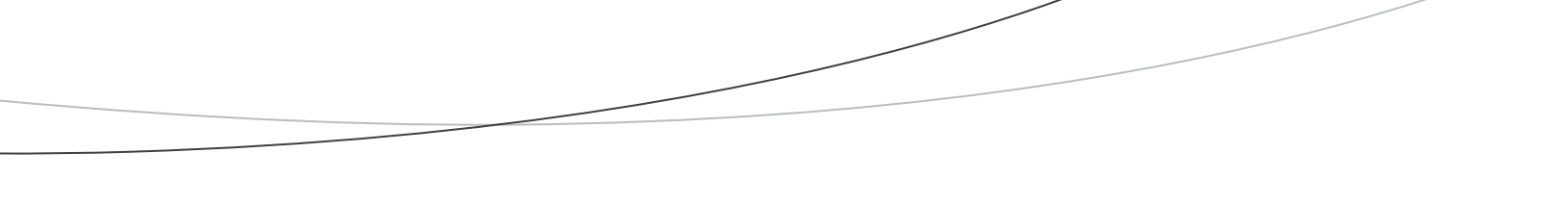



Ingersoll Rand's Security Technologies Sector is a leading global provider of products and services that make environments safe, secure and productive. The Sector's market-leading products include electronic and biometric access control systems; time and attendance and personnel scheduling systems; mechanical locks and portable security, door closers and exit devices, steel doors and frames, architectural hardware and technologies and services for global security markets.

[www.ingersollrand.com](http://www.ingersollrand.com)