



DESIGNED SECURITY, INC.

A Detex Company

Pricing and Options



This section of the catalog contains the published list prices for the following **Designed Security, Inc.** product lines:

- Access control products
- Annunciator products
- Optical turnstiles
- Tailgate detection
- Full height turnstiles

Prices for custom products will be furnished at list price, on an RFQ basis and the assigned Security Integrator discount levels will apply to these products.

For additional product information, technical assistance or to place an order please contact DSI:

Phone: 512-321-4426 or 800-272-3555

Fax: 512-321-9181

1. All **prices quoted** in United States Dollars. Terms are: Prepay by check or cash prior to shipment or COD. Net 30 upon approved credit, or prepaid wire transfer upon approval. For cash in advance orders, remittance must be received before goods ship. **All payments must be made in U.S. Dollars. All prices are subject to change without notice.**
2. **Purchase Orders** are required with all orders and must be written, signed by an authorized party, and received in original or facsimile form.
3. Expedite Fee of 20% may be added to any custom orders needed faster than quoted lead time. Expedite of Custom Orders may not be possible on every Custom Product. Please contact DSI for information.
4. All **shipments** are FOB Factory (Bastrop, Texas) and applicable Sales and Use tax will apply.
5. A **35% deposit** is required on all Optical Turnstiles and certain custom orders, and is due with signed submittals.
6. A **crating fee** of \$200 per bollard will be charged for all Optical Turnstile orders.
7. **Non-stock items** are subject to industry standard lead times.
8. Designed Security, Inc. **warranties** the Door Management and Annunciator products for one (1) complete year and all of the turnstiles for three (3) complete years from date of purchase. This includes the Optical Turnstiles and Full Height Turnstiles.
9. The purchaser shall **inspect the goods** upon receipt to determine that they are free of any defects or deficiencies. If the purchaser is not satisfied with the validity of the goods delivered, Designed Security, Inc. is to be advised immediately. Claims on defective products do not apply to products that have been subject to misuse (including static discharge), neglect, accident, modification, or products that have been soldered or altered. The issuing of credit or replacement of goods deemed defective is Designed Security, Inc.'s sole obligation, and in no event shall Designed Security, Inc.'s liability exceed the purchaser's original price.
10. In no event will Designed Security, Inc. be **liable** for lost profits, lost production, consequential or incidental damages arising out of, or relating to, any alleged or actual breach of warranty, negligence, strict liability in tort, delay in shipment, innocent or negligent misrepresentation, omission, or otherwise.
11. For **replacement or refund**, the defective products must be returned within thirty (30) days of the invoice date, accompanied by a copy of the invoice, and a Return Merchandise Authorization number (RMA) obtained from Designed Security, Inc. Goods returned without an RMA will be refused. If advanced replacement is necessary, a **Purchase Order is required**. If no problem is found with the unit in question, it will be returned and both the original and the **advanced replacement invoices will become due for payment**. Any product returned as a result of customer error must be returned within thirty (30) days of the invoice date and is subject to a restocking fee of twenty percent (20%). The product must be unused and the customer will pay the shipping fees to return the product.
12. Designed Security, Inc. is **not responsible for damage** incurred while the merchandise is in transit. The purchaser must file claims for loss or damaged goods in transit with the carrier.
13. Designed Security, Inc. reserves the right to make **product enhancement changes** without prior announcement.

ES411 Series DOOR PROP ALARM

ES411 - K

ES411	Door Prop Alarm		\$ 145.00
K <input type="checkbox"/>	No Key	Double Bit	Unit Price
0	✓		\$ 00.00
1		✓	\$ 28.00

EXAMPLE		ES411	
Door Prop Alarm with Double Bit Key Switch			
ES411	Door Prop Alarm		\$ 145.00
<u>K1</u>	Double Bit Key Switch		\$ 28.00
TOTAL			\$ 173.00

Legend:
K: Key Switch Option

ES411
ES4200
 ES4300
 ES440
 ES450
 ES4600
 ES500

ES4200 Series DOOR MANAGEMENT ALARM (DMA)

ES4200 - K - T

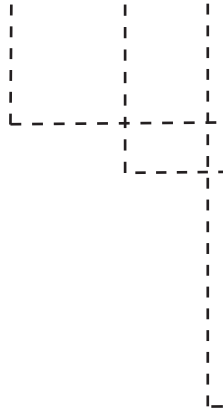

ES4200	Door Management Alarm				\$ 305.00
K <input type="checkbox"/>	No Key	Double Bit	Rim with Cylinder	Rim w/o Cylinder	Unit Price
0	✓				\$ 0.00
1		✓			\$ 6.00
3			✓		\$ 175.00
4				✓	\$ 120.00
T <input type="checkbox"/>	Tamper Switch				Unit Price
0	-				\$ 0.00
1	✓				\$ 20.00

EXAMPLE	ES4200	
Door Management Alarm with Rim without Cylinder and Tamper Switch		
ES4200	Door Management Alarm	\$ 305.00
K4	Rim without Cylinder	\$ 120.00
T1	Tamper Switch	\$ 20.00
TOTAL		\$ 445.00

Legend:
 K: Key Switch Option
 T: Tamper Switch

ES4300A Series EXIT ALARM (EA)

ES4300 - K - T

ES4300	Exit Alarm						\$ 264.00
K <input type="checkbox"/>	No Key	Double Bit	Barrel	Rim with Cylinder	Rim w/o Cylinder	DPDT	Unit Price
0	✓						\$ 0.00
1		✓					\$ 6.00
2			✓				\$ 30.00
3				✓			\$ 175.00
4					✓		\$ 120.00
6						✓	\$ 32.00
T <input type="checkbox"/>	Tamper Switch						Unit Price
0	-						\$ 0.00
1	✓						\$ 20.00

ES411 ES4200 **ES4300** ES440 ES450 ES4600 ES500

EXAMPLE		ES4300A	
Exit Alarm with Barrel Key Switch and Tamper Switch			
ES4300A	Exit Alarm		\$ 264.00
K2	Barrel Key Switch		\$ 30.00
T1	Tamper Switch		\$ 20.00
TOTAL			\$ 314.00

Legend:
 K: Key Switch Option
 T: Tamper Switch

ES411
ES4200
ES4300
ES440
ES450
ES4600
ES500

ES440 Series PUSHBUTTON CONTROL

ES44□- B□ - C□

ES44□	Pushbutton Control	Unit Price
0	1 gang painted aluminum plate	\$ 125.00
1	1 gang stainless steel plate	\$ 65.00
2	Mullion mount trim plate	\$ 98.00

B□	Shroud	Medium Mushroom	Large Mushroom	Alternate Action	Push/Pull	Key Release	Unit Price
1	✓						\$ 10.00
2		✓					\$ 26.00
3			✓				\$ 30.00
4				✓			\$ 53.00
5					✓		\$ 43.00
6						✓	\$ 91.00

C□	N/O	N/C	Time Delay Relay TDR	Pneumatic TDR	Unit Price
1	✓				\$ 6.00
2		✓			\$ 6.00
3	✓	✓			\$ 18.00
4			✓ ¹		\$ 99.00
5	✓		✓ ¹		\$ 116.00
6		✓	✓ ¹		\$ 116.00
7		(2) ✓			\$ 18.00
8	(2) ✓				\$ 18.00
9				✓ ²	\$ 198.00
10	✓	✓	✓ ¹		\$ 144.00

¹ Time Delay Relay includes 2 separate form C time-delayed contacts

² Pneumatic Time Delay Relay includes 1 N/O and 1 N/C time-delayed contact

EXAMPLE		ES441 - B3 - C3	
Pushbutton Control with a one gang stainless steel plate, a large mushroom pushbutton with one normally open (N/O) and one normally closed (N/C) contact			
ES44 <u>1</u>	Pushbutton Control		\$ 65.00
B <u>3</u>	Large Mushroom Pushbutton		\$ 30.00
C <u>3</u>	N/O and N/C contacts		\$ 18.00
TOTAL			\$ 113.00

Legend:
B: Button Options
C: Contact Options

ES450 Series KEY SWITCH CONTROL

ES45□ - K □

ES45□	Key Switch Control	
0	1 gang painted aluminum plate	\$ 65.00
1	1 gang stainless steel plate	\$ 53.00
2	Mullion mount trim plate	\$ 84.00

K □	Double Bit	Barrel	Rim with Cylinder	Rim w/o Cylinder	Medico	DPDT	Unit Price
1	✓						\$ 6.00
2		✓					\$ 30.00
3			✓				\$ 175.00
4				✓			\$ 120.00
5					✓		\$ 131.00
6						✓	\$ 32.00

Note: The ES452 does not accomodate rim hardware or cylinder

ES411 ES4200 ES4300 ES440 **ES450** ES4600 ES500

EXAMPLE		ES451
Key Switch Control with a one gang stainless steel plate and Rim with Cylinder		
ES451	Key Switch with one gang stainless steel plate	\$ 53.00
K3	Rim with Cylinder	\$ 175.00
TOTAL		\$ 228.00

Legend:
K: Key Switch Option

ES411
ES4200
ES4300
ES440
ES450
ES4600
ES500

ES4600 Series VOICE PROMPT DOOR MANAGEMENT ALARM

ES4600 - K - T

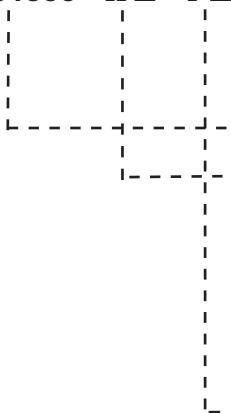

ES4600	Voice Prompt Door Management Alarm				\$ 397.00
K <input type="checkbox"/>	No Key	Double Bit	Rim with Cylinder	Rim w/o Cylinder	Unit Price
0	✓				\$ 0.00
1		✓			\$ 6.00
3			✓		\$ 175.00
4				✓	\$ 120.00
T <input type="checkbox"/>	Tamper Switch				Unit Price
0	-				\$ 0.00
1	✓				\$ 20.00

EXAMPLE		ES4600 - K1 - T0
Voice Prompt Door Management Alarm (DMA) with Double Bit Key Switch without Tamper Switch		
ES4300A	Exit Alarm	\$ 397.00
K1	Double Bit Key Switch	\$ 6.00
T0	No Tamper Switch	\$ 0.00
TOTAL		\$ 403.00

Legend:
K: Key Switch
T: Tamper Switch

ES500 Series BATTERY OPERATED EXIT ALARM

ES500	Base unit	\$ 160.00
ES500W	Weatherized base unit	\$ 225.00
ES500 xMC65	Base unit with mortise cylinder	\$ 224.00
ES500W xMC65	Base unit with mortise cylinder and weatherized	\$ 287.00

ES411 ES4200 ES4300 ES440 ES450 ES4600 **ES500**

ES520

ES5200 Series TAILGATE DETECTION SYSTEM

ES520 □ - R □

ES520□	Tailgate Detection System	
0	Standard Tailgate Unit	\$ 2990.00
1	Standard Tailgate Unit with spacer/mounting kit	\$ 3325.00
R □	Remote Annunciater Plate	Unit Price
0	None	\$ 0.00
1	1 gang plate	\$ 131.00
2	Mullion mount plate	\$ 146.00

EXAMPLE

ES5200 - R1

Standard Tailgate Detection System
with a one gang plate remote annunciator

ES5200	Tailgate Detection System	\$ 2990.00
R1	One gang remote annunciater plate	\$ 131.00
TOTAL		\$ 3121.00

Legend:
R: Remote annunciator plate

ES610 Series 4 ZONE ANNUNCIATOR

ES61 □

ES61 □		Unit Price
0	1 gang	\$ 215.00
1	1 gang with shunt	\$ 274.00
2	2 gang with N/O relay	\$ 314.00
3	2 gang with shunt & N/O relays	\$ 389.00
4	2 gang with supervision	\$ 305.00
5	2 gang with supervision & shunt	\$ 367.00

ES620 Series 8 ZONE ANNUNCIATOR

ES62 □

ES62 □		Unit Price
0	2 gang	\$ 370.00
1	2 gang with shunt	\$ 425.00
2	3 gang with N/O relays	\$ 534.00
3	3 gang with shunt & N/O relays	\$ 575.00
4	3 gang with supervision	\$ 493.00
5	3 gang with supervision & shunt	\$ 595.00

ES630 Series 12 ZONE ANNUNCIATOR

ES63 □

ES63 □		Unit Price
0	3 gang	\$ 483.00
1	3 gang with shunt	\$ 593.00
2	4 gang with N/O relays	\$ 925.00
3	4 gang with shunt & N/O relays	\$ 1248.00
4	4 gang with supervision	\$ 918.00
5	4 gang with supervision & shunt	\$ 1,242.00

ES760 ES750 ES600

ES750 Series RACK CONTROL PANEL

ES75 - Q / P

ES75 <input type="checkbox"/>		Unit Price
0	1.75" x 19" Rack Control Panel	\$ 364.00
1	3.50" x 19" Rack Control Panel	\$ 430.00
2	5.25" x 19" Rack Control Panel	\$ 497.00
Q	Quantity of Options "P"	

P <input type="checkbox"/> <input type="checkbox"/>	mom. action	alt. action	momentary action with integrated LED	alternate action with integrated LED	Momentary action with incandescent bulb	alternate action with incandescent bulb	LED annun. with resistor & terminal	Engraved lens	SPST barrel key switch	rim hdw with cylinder	rim hdw w/o cylinder	audible sounder	unit price
01	✓												\$ 50.00
02		✓											\$ 50.00
03			✓										\$ 70.00
04				✓									\$ 70.00
05					✓								\$ 60.00
06						✓							\$ 60.00
07							✓						\$ 34.00
08								✓					\$ 10.00
09									✓				\$ 34.00
10										✓			\$ 164.00
11											✓		\$ 118.00
12												✓	\$ 47.00

EXAMPLE

ES751 - Q03/P02-Q02/P05 - Q02/P08

3.5" x 19" Rack Control Panel with three (3) alternate action pushbuttons,
two (2) momentary action pushbuttons with incandescent bulbs,
and two (2) engraved lenses.

ES751	Rack Control Panel	\$ 430.00
Q03/P02	3 @ \$ 50.00	\$ 150.00
Q02/P05	2 @ \$ 60.00	\$ 120.00
Q02/P08	2 @ \$ 10.00	\$ 20.00
TOTAL		\$ 720.00

Legend:

Q: Quantity of options "P"

P: Pushbutton, key switch, and sounder options

ES760 Series KNEE SPACE UNIT

ES76 □ - Q□□ / P□□

ES76□		Unit Price
0	3" x 3" x 1.6" deep housing	\$ 112.00
1	4" x 3" x 1.6" deep housing	\$ 142.00
2	5" x 3" x 1.6" deep housing	\$ 172.00
3	6" x 3" x 1.6" deep housing	\$ 202.00
4	7" x 3" x 1.6" deep housing	\$ 232.00
Q □□	Quantity of Options "P"	
P □□	Momentary action button	SPST barrel key switch
01	✓	\$ 50.00
02		✓
		\$ 34.00

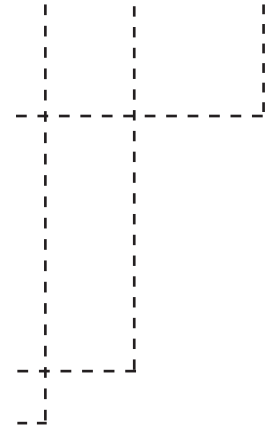

ES761 - Q02/P01-Q01/P02

4" x 3" x 1.6" deep knee space unit with two (2) alternate action pushbuttons, and one (1) SPST barrel key switch

ES761	Knee space housing	\$ 142.00
Q02/P01	2 @ \$ 50.00	\$ 100.00
Q01/P02	2 @ \$ 34.00	\$ 34.00
TOTAL		\$ 276.00

Legend:
 Q: Quantity of options "P"
 P: Pushbutton, key switch and sounder options

ES810 ES810 FP810 ES820 ES820 ES831 ES831 FP831 ES840 ES840 FP840 ES850 ES850 FP850 ES860 ES860 FP860 ES870

ES810 Series OPTICAL TURNSTILE

ES81 □ - N □

ES81 □	Base configuration	Unit price
0	Single direction - first walkway consists of two (2) bollards	\$ 17,970.00
1	Bi-directional - first walkway consists of two (2) bollards	\$ 19,389.00
N □	Number of adjacent walkways	Unit price
0	Single direction adjacent	\$ 11,037.00
1	Bi-directional adjacent	\$ 12,456.00

EXAMPLE

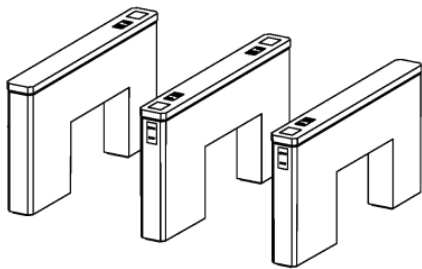

ES81 <u>1</u>	First walkway	\$ 19,389.00
N <u>1</u>	One (1) adjacent bi-directional walkway	\$ 12,456.00
TOTAL		\$ 31,845.00

EXAMPLE

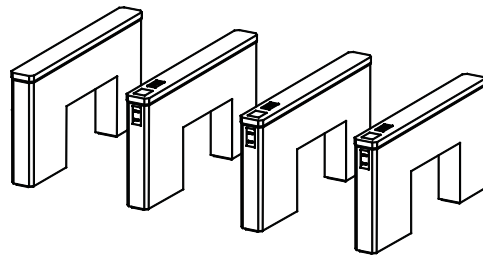

ES81 <u>0</u>	First walkway	\$ 17,970.00
N <u>2</u>	Two (2) adjacent bi-directional walkway	\$ 22,074.00
TOTAL		\$ 40,044.00

Legend:
N: Number of adjacent walkway floor plates

ES810 Series FLOOR PLATES

FP810 - N □

FP810	First walkway floor plate	\$ 3,750.00
N □	Number of adjacent walkways	Unit Price
	(1, 2, etc)	\$ 3,750.00

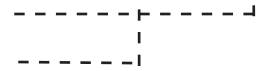

ES810
FP810
 ES820
 ES831
 FP831
 ES840
 FP840
 ES850
 FP850
 ES860
 ES870

EXAMPLE		
FP811-N1		
FP811 series floor plates		
two (2) walkways		
FP811	First walkway floor plate	\$ 3,750.00
N1	One (1) adjacent walkway floor plate	\$ 3,750.00
TOTAL		\$ 7,500.00

Legend:
 N: Number of adjacent walkway floor plates

ES810
FP810
ES820
ES831
FP831
ES840
FP840
ES850
FP850
ES860
ES870

ES820 Series OPTICAL TURNSTILE

ES82 □ - N □

ES82 □	Base configuration	Unit price
0	Single direction - components	\$ 6,096.00
1	Bi-directional - components	\$ 7,224.00
N □	Number of adjacent walkways	Unit Price
(1, 2, ... etc)	Single direction - adjacent	\$ 6,096.00
(1, 2, ... etc)	Bi-directional - adjacent	\$ 7,224.00

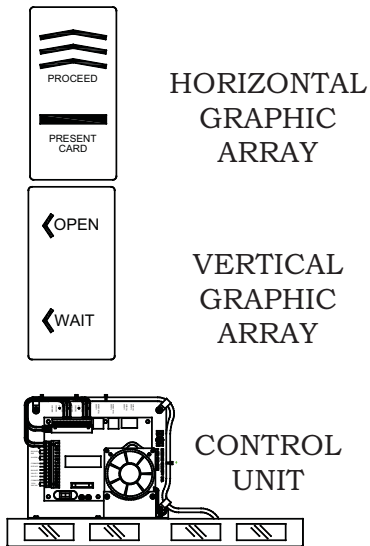

	Quantity		
	ES820	ES821	ES821
HORIZONTAL GRAPHIC ARRAY	1	1	2
VERTICAL GRAPHIC ARRAY	2	2	2
CONTROL UNIT	1	1	1

Note: all cables for connection between control unit and graphic arrays are included. 12 volt, 6 amp transformers are also provided.

ES831 Series OPTICAL TURNSTILE WITH BARRIER ARM

ES831 - N □

ES831	Optical turnstile with barrier arm	\$ 32,000.00
N □	Number of adjacent walkways	Unit Price
(1, 2,... Etc)	Bi-directional adjacent	\$ 32,000.00

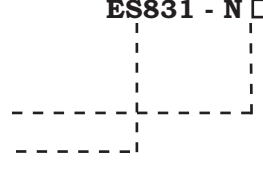

EXAMPLE

ES831	First walkway	\$ 32,000.00
N1	One (1) adjacent bi-directional walkway	\$ 32,000.00
TOTAL		\$ 64,000.00

Legend:
N: Number of walkways

ES810
FP810
ES820
ES831
FP831
ES840
FP840
ES850
FP850
ES860
ES870

ES810
ES810
FP810
ES820
ES831
FP831
ES840
ES840
FP840
ES850
ES850
FP850
ES860
ES860
ES870

ES831 Series FLOOR PLATES

FP831 □ - **N** □

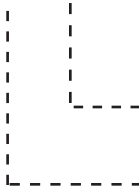

FP831	First walkway floor plate	\$ 3,825.00
N □	Number of adjacent walkways	Unit Price
	(1, 2,... Etc)	\$ 3,825.00

EXAMPLE		FP831-N1
ES831 series floor plates two (2) walkways		
FP831	First walkway floor plate	\$ 3,825.00
<u>N1</u>	One (1) adjacent floor plate walkway	\$ 3,825.00
TOTAL		\$ 7,650.00

Legend:
N: Number of adjacent walkway floorplates

ES840 Series COMPACT OPTICAL TURNSTILE

ES840 - N □

ES840	First walkway consists of two (2) pedestals	\$ 6,000.00
N □	Number of adjacent walkways	Unit Price
(1, 2,... Etc)	Bi-directional adjacent	\$ 3,600.00

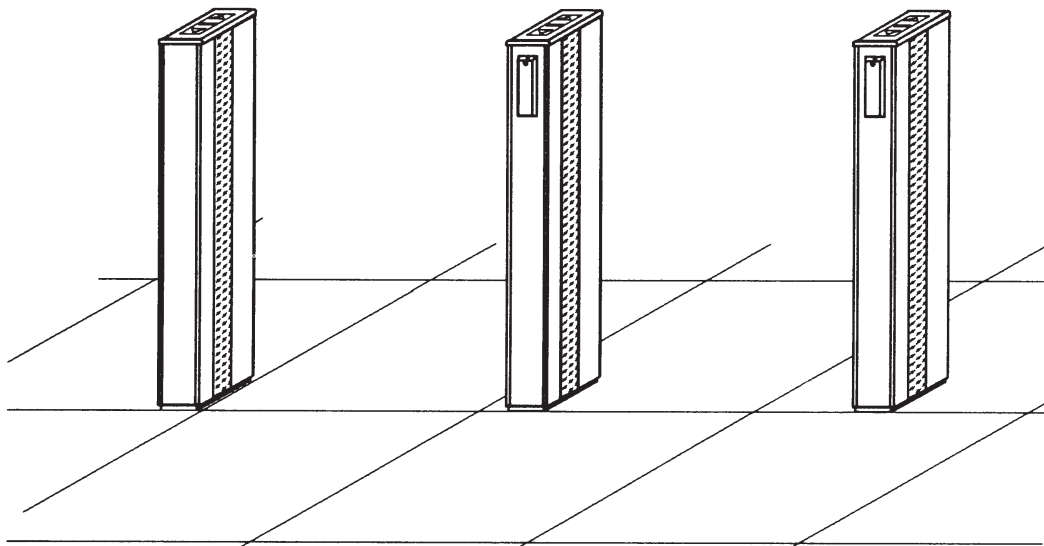

EXAMPLE		
ES840-N1		
Compact optical turnstile two (2) walkways		
FP840	First walkway	\$ 6,000.00
N1	One (1) adjacent walkway	\$ 3,600.00
TOTAL		\$ 9,600.00

Legend:
N: Number of adjacent walkways

ES810
FP810
ES820
ES831
FP831
ES840
FP840
ES850
FP850
ES860
ES870

ES810
ES810
FP810
ES820
ES831
ES831
FP831
ES840
FP840
ES850
ES850
FP850
ES860
ES860
FP850
ES870

ES840 Series FLOOR PLATES

FP84□ - N□

FP840	First walkway floor plate	\$ 1,225.00
N □	Number of adjacent walkways	Unit Price
	(1, 2,... Etc)	\$ 1,225.00

EXAMPLE	FP840-N1	
	ES840 series floor plates	
	two (2) walkways	
FP840	First walkway floor plate	\$ 1,225.00
N1	One (1) adjacent floor plate walkway	\$ 1,225.00
TOTAL		\$ 2,450.00

Legend:
N: Number of adjacent walkway floorplates

ES850 Series MID-SIZED OPTICAL TURNSTILE

ES850 - N □

ES850	First walkway consists of two (2) pedestals	\$ 8,500.00
N □	Number of adjacent walkways	Unit Price
(1, 2,... Etc)	Bi-directional adjacent	\$ 5,500.00

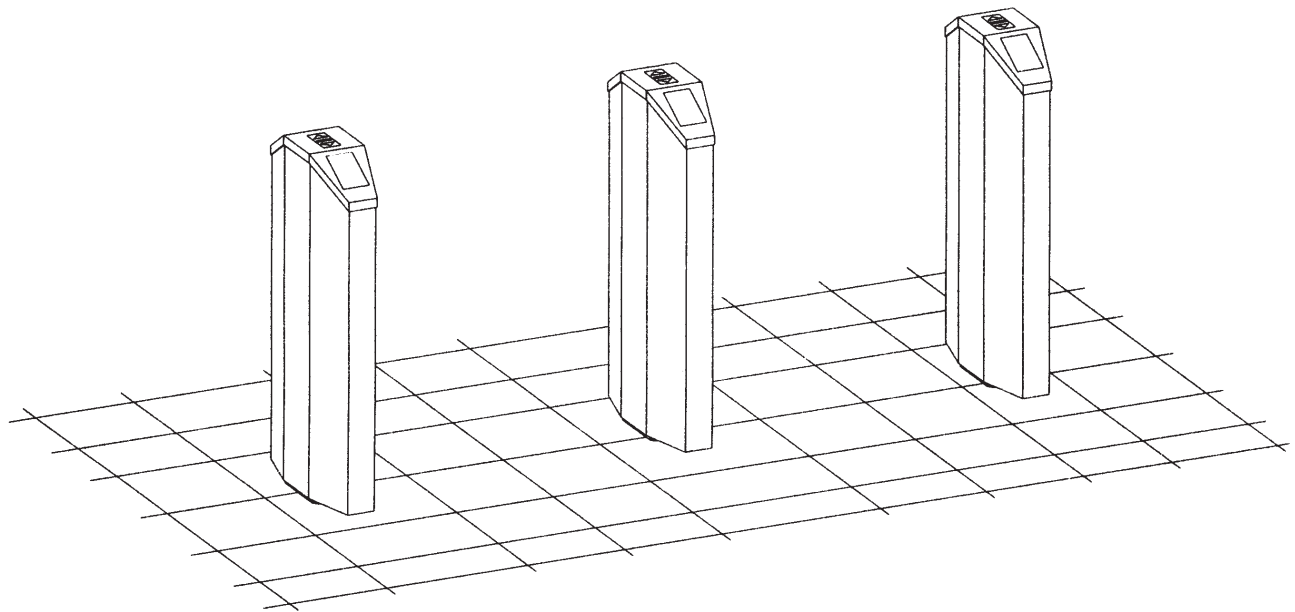

EXAMPLE		
ES840-N1		
Compact optical turnstile two (2) walkways		
FP850	First walkway	\$ 8,500.00
N1	One (1) adjacent walkway	\$ 5,500.00
TOTAL		\$ 14,000.00

Legend:
N: Number of adjacent walkways

ES810
FP810
ES820
ES831
FP831
ES840
FP840
ES850
FP850
ES860
ES870

ES810 ES810 ES810 ES820 ES831 ES831 ES840 ES840 ES850 **FP850** ES860 ES870

ES850 Series FLOOR PLATES

FP85 □ - N □

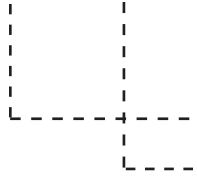

FP850	First walkway floor plate	\$ 1,225.00
N □	Number of adjacent walkways	Unit Price
	(1, 2,... Etc)	\$ 1,225.00

EXAMPLE		FP850-N1	
ES850 series floor plates			
two (2) walkways			
FP850	First walkway floor plate	\$	1,225.00
N1	One (1) adjacent floor plate walkway	\$	1,225.00
TOTAL		\$	2,450.00

Legend:
N: Number of adjacent walkway floorplates

ES860 Series CANISTER STYLE OPTICAL TURNSTILE

ES860 - N □

ES860	First walkway consists of two (2) pedestals	\$ 10,500.00
N □	Number of adjacent walkways	Unit Price
(1, 2,... Etc)	Bi-directional adjacent	\$ 6,700.00

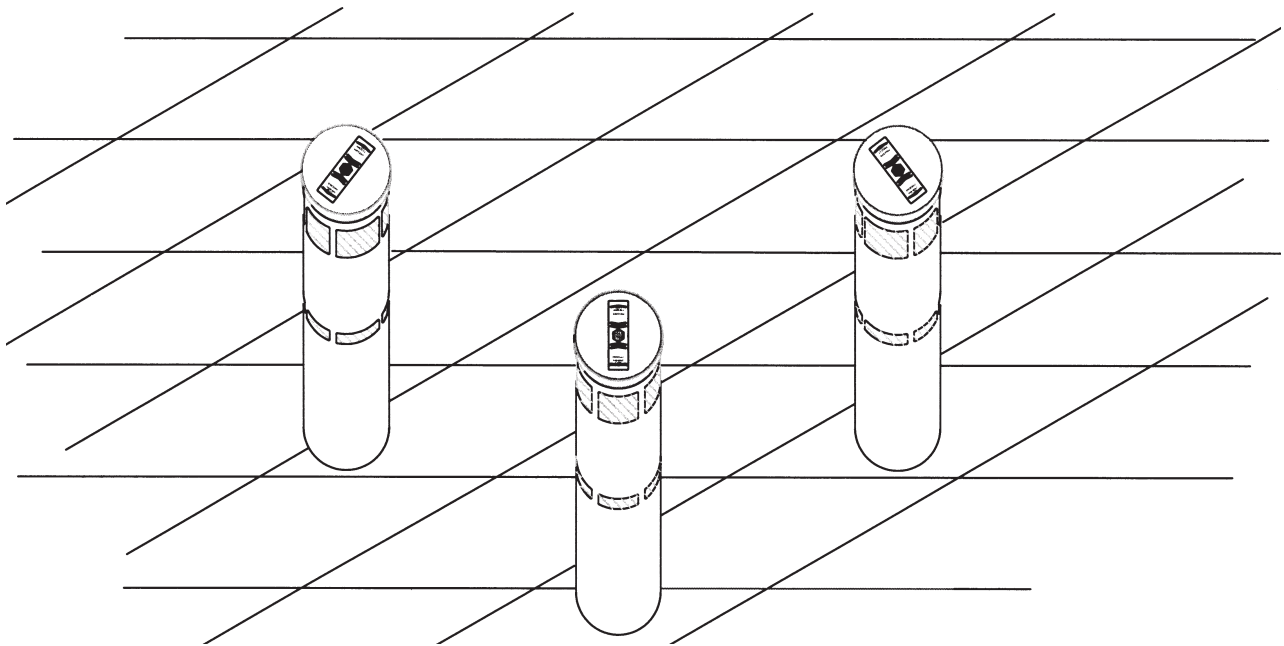

EXAMPLE		
ES860-N1		
Compact optical turnstile two (2) walkways		
FP860	First walkway	\$ 10,500.00
N1	One (1) adjacent walkway	\$ 6,700.00
TOTAL		\$ 17,200.00

Legend:
N: Number of adjacent walkways

ES810
FP810
ES820
ES831
FP831
ES840
FP840
ES850
FP850
ES860
ES870

ES810
ES810
FP810
ES820
ES831
ES831
FP831
ES840
ES840
FP840
ES850
ES850
FP850
ES860
ES870

ES870 Series STEREO VISION OPTICAL TURNSTILE WITH BARRIER ARM

ES870 - N

ES870	Stereo Vistion Optical Turnstile with Barrier Arm	\$ 45,000.00
N <input type="checkbox"/>	Number of adjacent walkways	Unit Price
(1, 2,... Etc)	Bi-directional adjacent	\$ 45,000.00

EXAMPLE

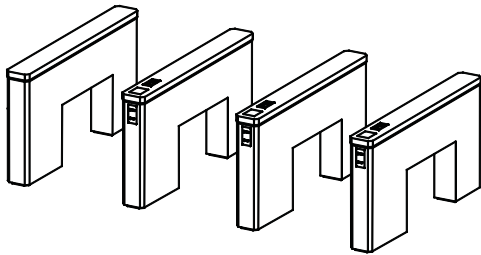

ES870	First walkway	\$ 45,000.00
N ₁	One (1) adjacent bi-directional walkway	\$ 45,000.00
TOTAL		\$ 90,000.00

Legend:
N: Number of walkways

TYPE	FINISH	CONFIGURE	ENTRANCE 1	EXIT 1	DOUBLE UNIT ONLY	
					ENTRANCE 2	EXIT 2
DS-FAL	C - clear anodize B - bronze anodize	S - single D - double	1 - fail safe	1 - fail safe	1 - fail safe	1 - fail safe
			2 - fail secure	2 - fail secure	2 - fail secure	2 - fail secure
			3 - not used	3 - not used	3 - not used	3 - not used
			4 - manual	4 - manual	4 - manual	4 - manual

ALUMINUM SINGLE UNITS WITH CLEAR COLOR ANODIZE FINISH

DS-FALCS13	1-way Electric, Ent. 1 Fail-Safe, Ext. Locked	\$ 9,947.00
DS-FALCS23	1-way Electric, Ent. 1 Fail-Secure, Ext.1 Locked	\$ 9,947.00
DS-FALCS31	1-way Electric, Ent. 1 Locked, Ext.1 Fail-Safe	\$ 9,947.00
DS-FALCS32	1-way Electric, Ent. 1 Locked, Ext. Fail-Secure	\$ 9,947.00
DS-FALCS34	1-way Manual, Ent. 1 Locked, Ext.1 Manual	\$ 8,843.00
DS-FALCS43	1-way Manual, Ent. 1 Manual, Ext.1 Locked	\$ 8,843.00
DS-FALCS11	2-way Electric, Ent. 1 Fail-Safe, Ext.1 Fail Safe	\$ 10,407.00
DS-FALCS21	2-way Electric, Ent. 1 Fail-Secure, Ext.1 Fail-Safe	\$ 10,407.00
DS-FALCS22	2-way Electric, Ent. 1 Fail-Secure, Ext.1 Fail-Secure	\$ 10,407.00

ALUMINUM SINGLE UNITS WITH BRONZE COLOR ANODIZE FINISH

DS-FALBS13	1-way Electric, Ent. 1 Fail-Safe, Ext.1 Locked	\$ 10,402.00
DS-FALBS23	1-way Electric, Ent. 1 Fail-Secure, Ext.1 Locked	\$ 10,402.00
DS-FALBS31	1-way Electric, Ent. 1 Locked, Ext.1 Fail-Safe	\$ 10,402.00
DS-FALBS32	1-way Electric, Ent. 1 Locked Ext.1 Fail-Secure	\$ 10,402.00
DS-FALBS34	1-way Manual, Ent. 1 Locked, Ext.1 Manual	\$ 9,304.00
DS-FALBS43	1-way Manual, Ent. 1 Manual, Ext.1 Locked	\$ 9,304.00
DS-FALBS11	2-way Electric, Ent. 1 Fail-Safe, Ext.1 Fail-Safe	\$ 10,862.00
DS-FALBS21	2-way Electric, Ent. 1 Fail-Secure, Ext. 1 Fail-Safe	\$ 10,862.00
DS-FALBS22	2-way Electric, Ent. 1 Fail-Secure, Ext.1 Fail-Secure	\$ 10,862.00

ALUMINUM DOUBLE UNITS WITH CLEAR COLOR ANODIZE FINISH

DS-FALCD1313	1-way Electric, Ent. 1 & 2 Fail-Safe, Ext. 1 & 2 Locked	\$ 19,786.00
DS-FALCD2323	1-way Electric, Ent. 1 & 2 Fail-Secure, Ext.1 & 2 Locked	\$ 19,786.00
DS-FALCD3131	1-way Electric, Ent. 1 & 2 Locked, Ext.1 & 2 Fail-Safe	\$ 19,786.00
DS-FALCD3232	1-way Electric, Ent. 1 & 2 Locked, Ext.1 & 2 Fail-Secure	\$ 19,786.00
DS-FALCD1331	1-way Electric, Ent. 1 Fail-Safe, Ent. 2 Locked, Ext. 1 Locked, Ext. 2 Fail-Safe	\$ 19,786.00
DS-FALCD2331	1-way Electric, Ent. 1 Fail-Secure, Ent.2 Locked, Ext.1 Locked, Ext. 2 Fail-Safe	\$ 19,786.00
DS-FALCD2332	1-way Electric, Ent. 1 Fail-Secure, Ent.2 Locked, Ext.1 Locked, Ext. 2 Fail-Secure	\$ 19,786.00
DS-FALCD3434	1-way Manual, Ent. 1 & 2 Locked, Ext.1 & 2 Manual	\$ 19,078.00
DS-FALCD4343	1-way Manual, Ent. 1 & 2 Manual, Ext. 1 & 2 Locked	\$ 19,078.00
DS-FALCD4334	1-way Manual, Ent. 1 Manual, Ent. 2 Locked, Ext. 1 Locked, Ext. 2 Manual	\$ 19,078.00
DS-FALCD1111	2-way Electric, Ent. 1 & 2 Fail-Safe, Ext. 1 & 2 Fail-Safe	\$ 20,625.00
DS-FALCD2121	2-way Electric, Ent. 1 & 2 Fail-Secure, Ext. 1 & 2 Fail-Safe	\$ 20,625.00
DS-FALCD2222	2-way Electric, Ent. 1 & 2 Fail-Secure, Ext. 1 & 2 Fail-Secure	\$ 20,625.00

ALUMINUM DOUBLE UNITS WITH BRONZE COLOR ANODIZE FINISH

DS-FALBD1313	1-way Electric, Ent. 1 & 2 Fail-safe, Ext. 1 & 2 Locked	\$ 20,668.00
DS-FALBD2323	1-way Electric, Ent. 1 & 2 Fail-Secure, Ext. 1 & 2 Locked	\$ 20,668.00
DS-FALBD3131	1-way Electric, Ent. 1 & 2 Locked, Ext. 1 & 2 Fail-Safe	\$ 20,668.00
DS-FALBD3232	1-way Electric, Ent. 1 & 2 Locked, Ext. 1 & 2 Fail-Secure	\$ 20,668.00
DS-FALBD1331	1-way Electric, Ent. 1 Fail-Safe, Ent. 2 Locked, Ext. 1 Locked, Ext. 2 Fail-Safe	\$ 20,668.00
DS-FALBD2331	1-way Electric, Ent. 1 Fail-Secure, Ent. 2 Locked, Ext. 1 Locked, Ext. 2 Fail-Safe	\$ 20,668.00
DS-FALBD2332	1-way Electric, Ent. 1 Fail-Secure, Ent. 2 Locked, Ext.1 Locked, Ext. 2 Fail-Secure	\$ 20,668.00
DS-FALBD3434	1-way Manual, Ent. 1 & 2 Locked, Ext. 1 & 2 Manual	\$ 19,975.00
DS-FALBD4343	1-way Manual, Ent. 1 & 2 Manual, Ext.1 & 2 Locked	\$ 19,975.00
DS-FALBD4334	1-way Manual, Ent. 1 Manual, Ent. 2 Locked, Ext.1 Locked, Ext. 2 Manual	\$ 19,975.00
DS-FALBD1111	2-way Electric, Ent. 1 & 2 Fail-Safe, Ext.1 & 2 Fail-Safe	\$ 21,522.00
DS-FALBD2121	2-way Electric, Ent. 1 & 2 Fail-Secure, Ext. 1 & 2 Fail-Safe	\$ 21,522.00
DS-FALBD2222	2-way Electric, Ent. 1 & 2 Fail-Secure, Ext.1 & 2 Fail-Secure	\$ 21,522.00

TYPE	CONFIGURE	ENTRANCE 1	EXIT 1	DOUBLE UNIT ONLY	
				ENTRANCE 2	EXIT 2
DS-FSTG	S - single	1 - fail safe	1 - fail safe	1 - fail safe	1 - fail safe
	D - double	2 - fail secure	2 - fail secure	2 - fail secure	2 - fail secure
		3 - not used	3 - not used	3 - not used	3 - not used
		4 - manual	4 - manual	4 - manual	4 - manual

GALVANIZED STEEL SINGLE UNITS

DS-FSTGS13	1-way Electric, Ent. 1 Fail-Safe, Ext. Locked	\$ 5,071.00
DS-FSTGS23	1-way Electric, Ent. 1 Fail-Secure, Ext.1 Locked	\$ 5,071.00
DS-FSTGS31	1-way Electric, Ent. 1 Locked, Ext.1 Fail-Safe	\$ 5,071.00
DS-FSTGS32	1-way Electric, Ent. 1 Locked, Ext. Fail-Secure	\$ 5,071.00
DS-FSTGS34	1-way Manual, Ent. 1 Locked, Ext.1 Manual	\$ 4,732.00
DS-FSTGS43	1-way Manual, Ent. 1 Manual, Ext.1 Locked	\$ 4,732.00
DS-FSTGS11	2-way Electric, Ent. 1 Fail-Safe, Ext.1 Fail Safe	\$ 5,549.00
DS-FSTGS21	2-way Electric, Ent. 1 Fail-Secure, Ext.1 Fail-Safe	\$ 5,549.00
DS-FSTGS22	2-way Electric, Ent. 1 Fail-Secure, Ext.1 Fail-Secure	\$ 5,549.00

GALVANIZED STEEL DOUBLE UNITS

DS-FSTGD13131	1-way Electric, Ent. 1 & 2 Fail-safe, Ext. 1 & 2 Locked	\$ 11,580.00
DS-FSTGD23231	1-way Electric, Ent. 1 & 2 Fail-Secure, Ext. 1 & 2 Locked	\$ 11,580.00
DS-FSTGD31311	1-way Electric, Ent. 1 & 2 Locked, Ext. 1 & 2 Fail-Safe	\$ 11,580.00
DS-FSTGD32321	1-way Electric, Ent. 1 & 2 Locked, Ext. 1 & 2 Fail-Secure	\$ 11,580.00
DS-FSTGD13311	1-way Electric, Ent. 1 Fail-Safe, Ent. 2 Locked, Ext. 1 Locked, Ext. 2 Fail-Safe	\$ 11,580.00
DS-FSTGD23311	1-way Electric, Ent. 1 Fail-Secure, Ent. 2 Locked, Ext. 1 Locked, Ext. 2 Fail-Safe	\$ 11,580.00
DS-FSTGD2332	1-way Electric, Ent. 1 Fail-Secure, Ent. 2 Locked, Ext.1 Locked, Ext. 2 Fail-Secure	\$ 11,580.00
DS-FSTGD34341	1-way Manual, Ent. 1 & 2 Locked, Ext. 1 & 2 Manual	\$ 11,017.00
DS-FSTGD43431	1-way Manual, Ent. 1 & 2 Manual, Ext.1 & 2 Locked	\$ 11,017.00
DS-FSTGD43341	1-way Manual, Ent. 1 Manual, Ent. 2 Locked, Ext.1 Locked, Ext. 2 Manual	\$ 11,017.00
DS-FSTGD11112	2-way Electric, Ent. 1 & 2 Fail-Safe, Ext.1 & 2 Fail-Safe	\$ 12,506.00
DS-FSTGD21212	2-way Electric, Ent. 1 & 2 Fail-Secure, Ext. 1 & 2 Fail-Safe	\$ 12,506.00
DS-FSTGD22222	2-way Electric, Ent. 1 & 2 Fail-Secure, Ext.1 & 2 Fail-Secure	\$ 12,506.00

ADA GATES

AT-FSFASWG-48 Anodized aluminum ADA gate
 ----- \$ 4,765.00

AT-FGSWG-48 Galvanized steel ADA gate
 ----- \$ 3,165.00

ACCESSORIES

ST-SLP-1 Red/green status light package, 1 way
 ----- \$ 270.00

ST-SLP-2 Red/green status light package, 2 way
 ----- \$ 395.00

ST-SLCRP-1 Red/green status light & card reader mount package, 1 way
 ----- \$ 375.00

ST-SLCRP-2 Red/green status light & card reader mount package, 2 way
 ----- \$ 735.00

Surface Mount Boxes

S1	Surface mount box - 1 gang -----	\$ 42.00
S2	Surface mount box - 2 gang -----	\$ 48.00
S3	Surface mount box - 3 gang -----	\$ 54.00

Power Supplies

PS/DC12	Plug-in regulated 1000mA - LED power indicator -----	\$ 29.00
PS/AC16	Plug-in transformer. LED and basic surge protection -----	\$ 15.00

Door Contacts

DC/HS30	Hidden wire - hidden screw - surface mount -----	\$ 5.00
PS/SD80	Steel door contact - 1" diameter - magnet -----	\$ 6.00

Locking Arms

----- \$ 2,500.00

Visitor Badge Return

----- \$ 2,500.00

Voice Option

----- \$ 2,000.00

Power Supply

----- \$ 650.00

Random Search

----- \$ 2,000.00

Visitor Bar Code Reader

----- \$ 6,500.00